

ENGLISH

**DDL-8700A-7
INSTRUCTION MANUAL**

CONTENTS

I . SPECIFICATIONS	1
II . SET-UP	3
1. Installation.....	3
2. Installing the pedal sensor	4
3. Installing the power switch.....	4
4. Attaching the connecting rod	6
5. Winding the bobbin thread	7
6. Adjusting the height of the knee lifter	8
7. Installing the thread stand	8
8. Lubrication	9
9. Adjusting the amount of oil (oil splashes)	9
10. Attaching the needle.....	11
11. Setting the bobbin into the bobbin case	12
12. Adjusting the stitch length.....	12
13. Presser foot pressure.....	12
14. Hand lifter	12
15. Adjusting the height of the presser bar.....	13
16. Threading the machine head	13
17. Thread tension	14
18. Thread take-up spring	14
19. Adjusting the thread take-up stroke	14
20. Needle-to-hook relationship	15
21. Height of the feed dog.....	15
22. Tilt of the feed dog.....	16
23. Adjusting the feed timing.....	16
24. Cunter knife.....	17
25. Pedal pressure and pedal stroke	17
26. Adjustment of the pedal.....	18
III . FOR THE OPERATOR	19
1. Operating procedure of the sewing machine.....	19
2. Built-in panel of the machine head	21
3. Operating procedure of the sewing pattern	22
4. One-touch setting	24
5. Production support function	25
6. Setting of functions	28
7. Function setting list.....	29
8. Detailed explanation of selection of functions	33
9. Automatic compensation of neutral point of the pedal sensor.....	43
10. Selection of the pedal specifications.....	43

11. Setting of the auto lifter function	44
12. Selecting procedure of the key-lock function	45
13. Removing the rear cover	46
14. Connection of the pedal of standing-work machine	48
15. External input / output connector	48
16. Connection of the material end sensor	49
17. Initialization of the setting data	50
IV . MAINTENANCE	51
1. Replacing the fuse	51
2. Adjusting the machine head	52
3. Connector layout drawing	53
4. Error codes	54

I . SPECIFICATIONS

Supply voltage	Single phase 100 to 120V	3-phase 200 to 240V	Single phase 220 to 240V
Frequency	50Hz/60Hz	50Hz/60Hz	50Hz/60Hz
Operating environment	Temperature : 5 to 35°C Humidity 35 - 85 % or less	Temperature : 5 to 35°C Humidity 35 - 85 % or less	Temperature : 5 to 35°C Humidity 35 - 85 % or less
Input	210VA	210VA	210VA

DDL-8700A - 7

S :	Medium-weight materials
H :	Heavy-weight materials

	DDL-8700AS-7	DDL-8700AH-7
Max. sewing speed	5,000 sti/min	4,000 sti/min
Thread trimming speed	300 sti/min	300 sti/min
Stitch length	4mm	5mm
Presser foot lift (by knee lifter)	13 mm	13 mm
Needle *1	DB x 1 (#14) #9 to 18	DB x 1 (#21) #20 to 23
Lubricating oil	JUKI MACHINE OIL #7	JUKI MACHINE OIL #7

- The sewing speed will vary depending on the sewing conditions.
- The sewing speed preset at the time of shipping AS-7 : 4,000sti/min.
..... AH-7 : 3,500sti/min.

*1 : Needle used depends on the destination.

Noise	- Equivalent continuous emission sound pressure level (L _{pA}) at the workstation : A-weighted value of 79.5 dB; (Includes K _{pA} = 2.5 dB); according to ISO 10821- C.6.2 -ISO 11204 GR2 at 4,000 sti/min.
-------	---

DRAWING OF TABLE

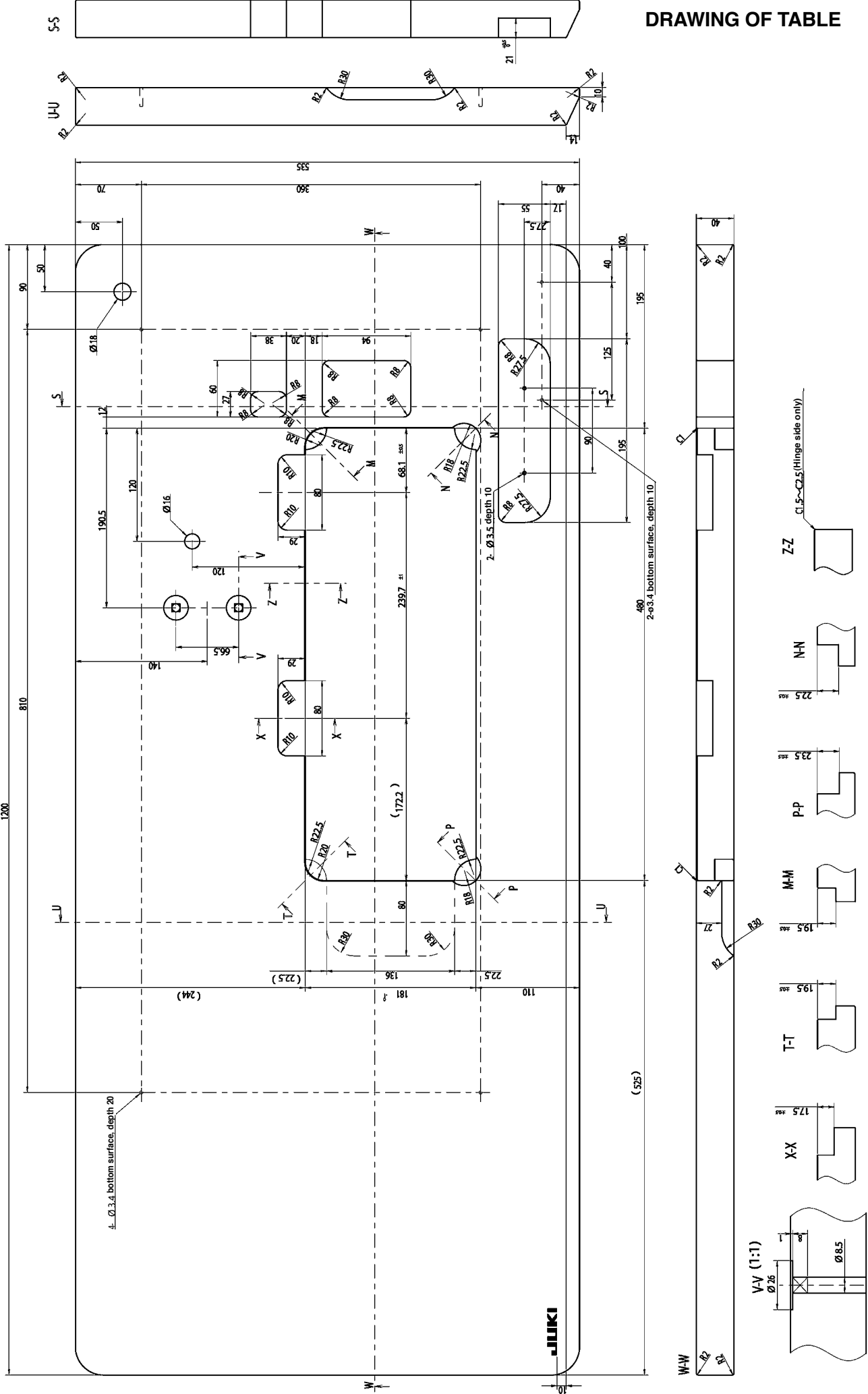

II. SET-UP

1. Installation

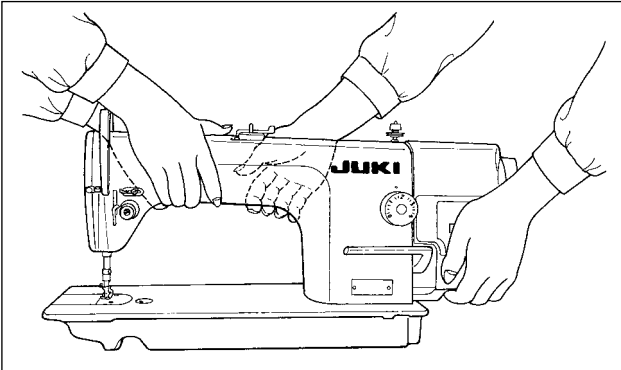

- 1) Carry the sewing machine with two persons as shown in the figure above.

(Caution) Do not hold the handwheel.

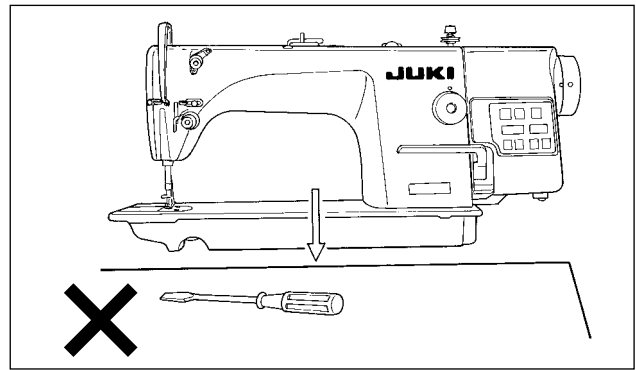
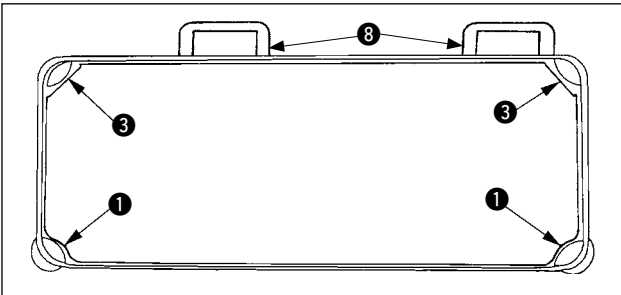

- 2) Do not put protruding articles such as the screwdriver and the like at the location where the sewing machine is placed.

- 3) The under cover should rest on the four corners of the machine table groove. Mount rubber hinge seat ⑧ on the table and fix it on the table with a nail.

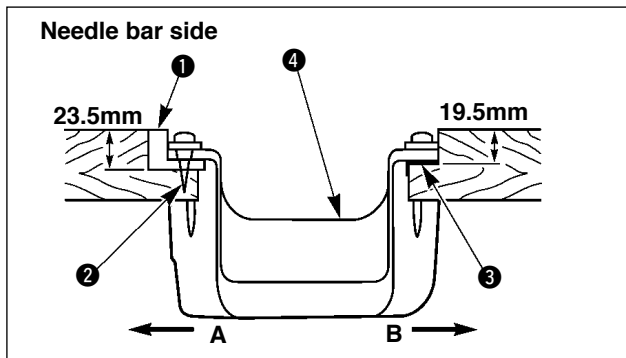

Control box side

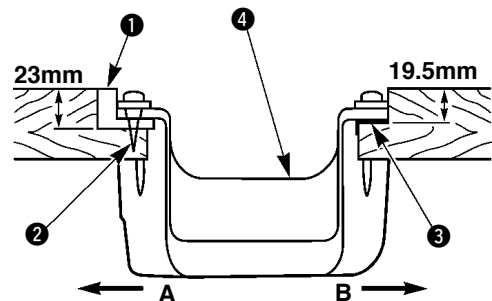

- 4) Fix two rubber seats ① on side A (operator's side) using nails ② as illustrated above. Fix two cushion seats ③ on side B (hinged side) using a rubber-based adhesive. Then place under cover ④ on the fixed seats.

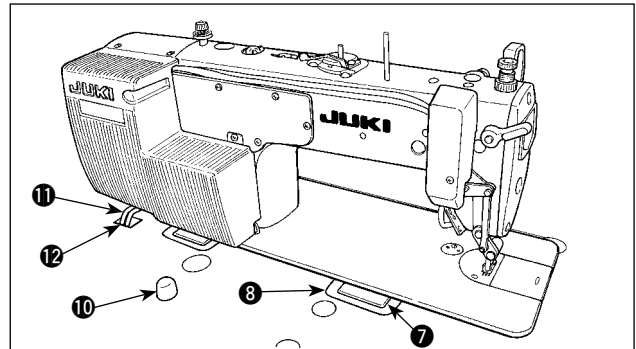
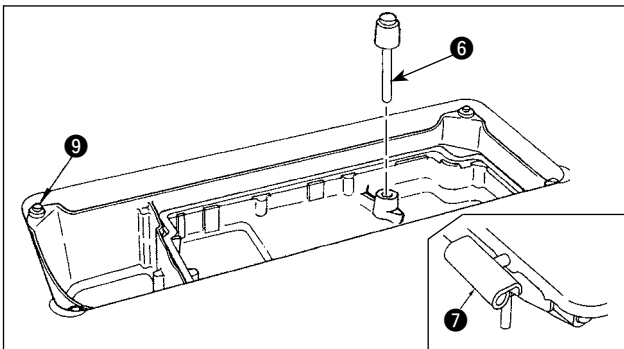

- 5) Fit knee lifter pressing rod ⑥. Fit hinge ⑦ into the opening in the machine bed, and fit the machine head to table rubber hinge ⑧ before placing the machine head on cushions ⑨ on the four corners.

- 6) Securely attach head support rod ⑩ to the table until it goes no further.

(Caution) Be sure to install the machine head support bar supplied with the unit.

- 7) Draw out cable ⑪ of the control box through cable draw-out hole ⑫ to route it to the underside of the sewing machine table.

2. Installing the pedal sensor

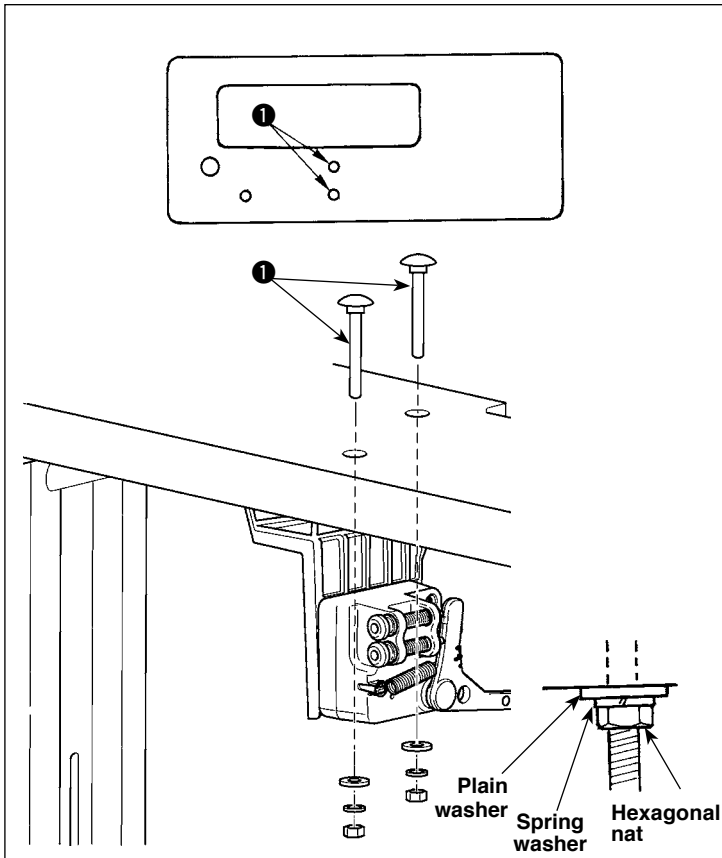

The explanation applies to the case the pedal sensor is installed on the table for the DDL-8700A-7.

- 1) Install the pedal sensor on the table by means of mounting bolt asm. ❶ supplied with the unit. At this time, insert the nut and washer supplied with the unit as accessories as shown in the figure so that the control box is securely fixed.
- 2) After the completion of installation of the pedal sensor on the table, place the sewing machine head on the table.

WARNING :



- To protect against personal injury resulting from abrupt start of the sewing machine, be sure to turn the power OFF, unplug the machine and wait for five minutes or more before installing the pedal sensor.
- To prevent damage of device caused by maloperation and wrong specifications, be sure to connect all the corresponding connectors to the specified places. (If any of the connectors is inserted into a wrong connector, not only the device corresponding to the connector can break but also it can start abruptly, inviting the risk of personal injury.)
- To prevent personal injury caused by maloperation, be sure to lock the connector with lock.
- As for the details of handling respective devices, read carefully the Instruction Manuals supplied with the devices before handling the devices.

3. Installing the power switch

(Caution) Do not insert the power plug into the plug receptacle.

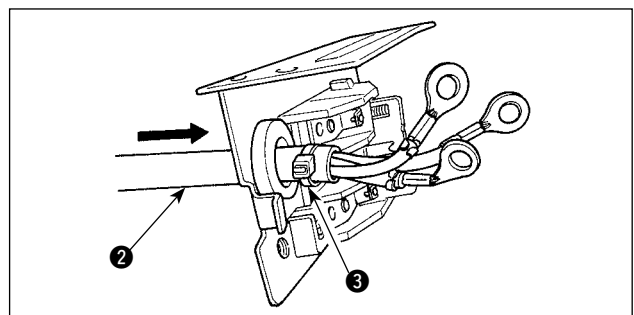
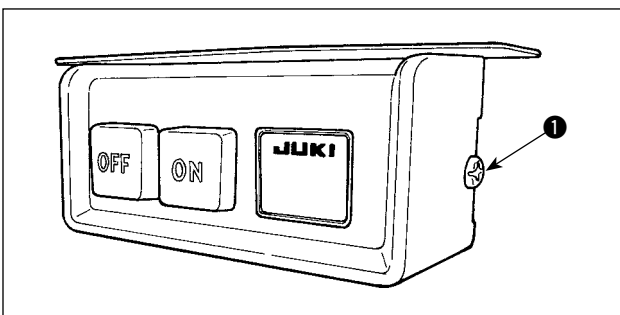

- 1) Remove screw ❶ on the side face of the power switch cover to open the power switch cover.

- 2) Pass AC input cord ❷ coming from the control box through the rear face of the power switch. Bundle the cord with cable clip band ❸ to secure it.

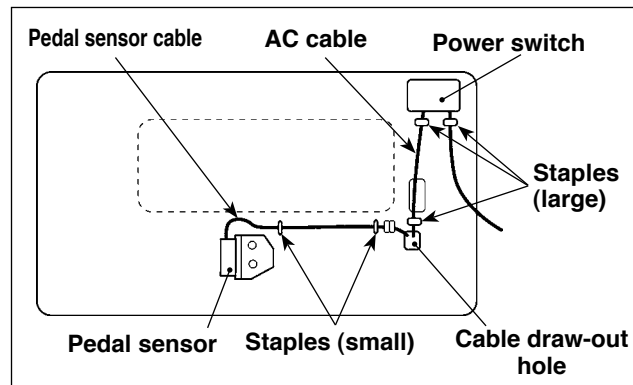
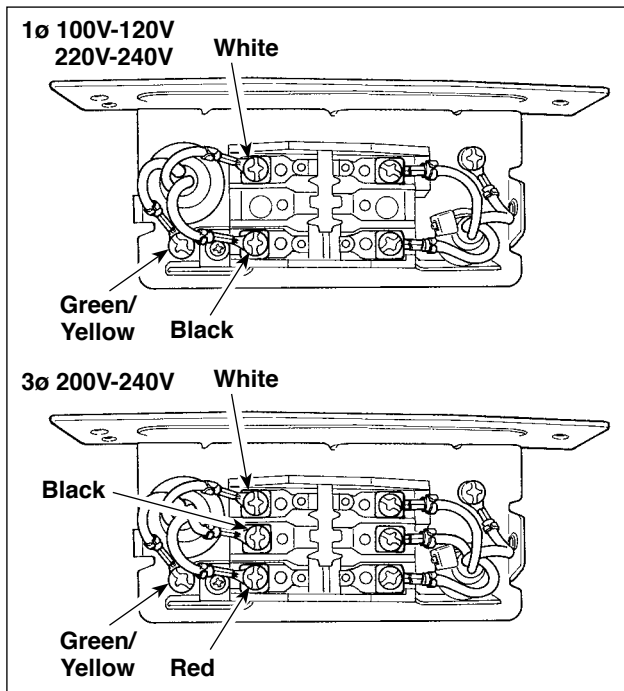

- 3) Securely fix the terminals of the AC input cord by tightening the screws at the specified locations.
- 4) Close the power switch cover. Tighten screw ❶ on the side face of the power switch cover.

- 5) Firstly attach the staple supplied with the unit as accessories to the cable. Then, hammer them into the sewing machine table. At this time, attach the staples at the locations shown in the figure.



WARNING :

1. Be sure to attach the ground wire (green/yellow) to the specified location (on the ground side).
2. Take care not to allow terminals to come in contact with each other.
3. When closing the power switch cover, take care not to allow the cord to be caught under it.

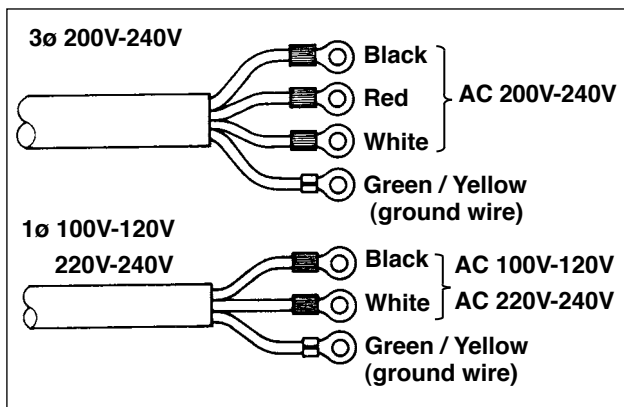

- 6) Connect the power cord to the power plug. As shown in the figure, connect the white and black (and red) wires to the power supply side and the green/yellow one to the grounding side.
(Caution) 1. Be sure to prepare the power plug ❸ which conforms to the safety standard.
2. Be sure to connect the ground lead (green/yellow) to the grounding side.

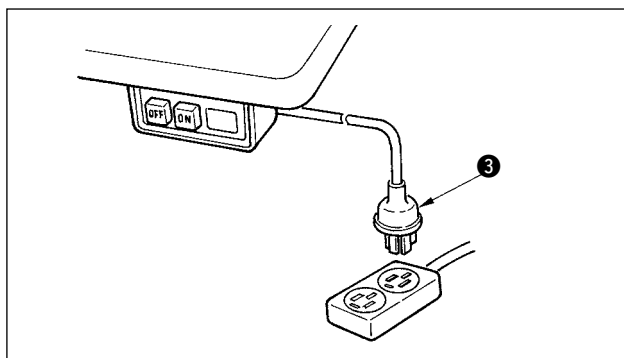

- 7) Check that the power switch is in the OFF state. Then, insert the power plug coming from the power switch into the plug receptacle.
(Caution) In prior to the connection of the power plug, re-check the supply voltage specification indicated on the power box.

4. Attaching the connecting rod



WARNING :

To protect against possible personal injury due to abrupt start of the machine, be sure to start the following work after turning the power off and a lapse of 5 minutes or more.

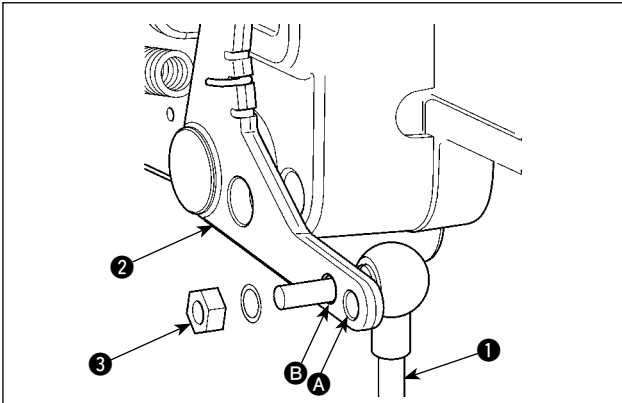

- 1) Fix connecting rod ① to installing hole ② of pedal lever ② with nut ③.
- 2) Installing connecting rod ① to installing hole ④ will lengthen the pedal depressing stroke, and the pedal operation at a medium speed will be easier.

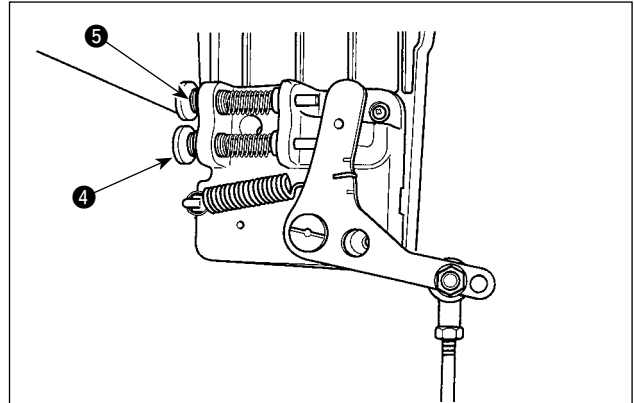

- 3) The pressure increases as you turn reverse depressing regulator screw ④ in, and decreases as you turn the screw out.

- (Caution)**
1. If the screw is excessively loosened, the spring will come off. Loosen the screw to such an extent that the top of the screw can be observed from the case.
 2. Whenever you have adjusted the screw, be sure to secure the screw by tightening metal nut ⑤ to prevent the screw from loosening.

5. Winding the bobbin thread

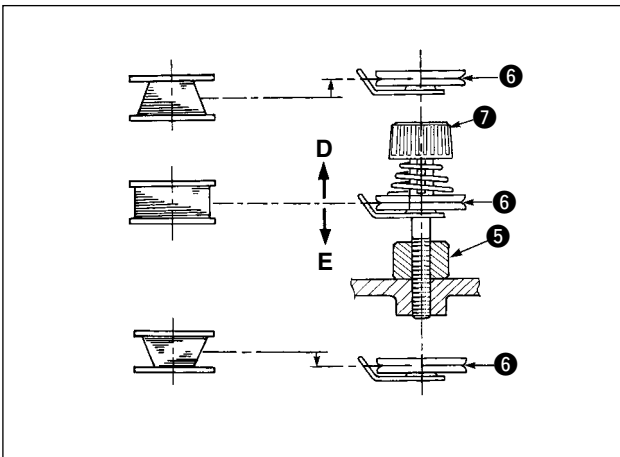
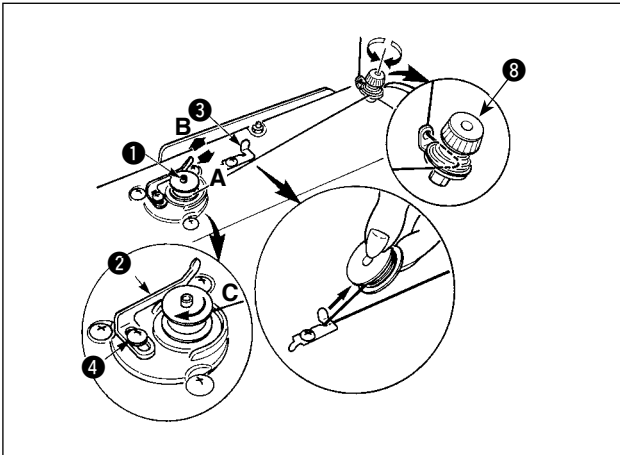

- 1) Insert the bobbin deep into the bobbin winder spindle ① until it will go no further.
- 2) Pass the bobbin thread pulled out from the spool rested on the right side of the thread stand following the order as shown in the figure on the left. Then, wind clockwise the end of the bobbin thread on the bobbin several times.
(In case of the aluminum bobbin, after winding clockwise the end of the bobbin thread, wind counterclockwise the thread coming from the bobbin thread tension several times to wind the bobbin thread with ease.)
- 3) Press the bobbin winder trip latch ② in the direction of **A** and start the sewing machine. The bobbin rotates in the direction of **C** and the bobbin thread is wound up. The bobbin winder spindle ① automatically as soon as the winding is finished.
- 4) Remove the bobbin and cut the bobbin thread with the thread cut retainer ③.
- 5) When adjusting the winding amount of the bobbin thread, loosen setscrew ④ and move bobbin winding lever ② to the direction of **A** or **B**. Then tighten setscrew ④.
To the direction of **A** : Decrease
To the direction of **B** : Increase

- 6) In case that the bobbin thread is not wound evenly on the bobbin, remove the handwheel, loosen screw ⑤ and adjust the height of bobbin thread tension ⑧.
 - It is the standard that the center of the bobbin is as high as the center of thread tension disk ⑥.
 - Adjust the position of thread tension disk ⑥ to the direction of **D** when the winding amount of the bobbin thread on the lower part of the bobbin is excessive and to the direction **E** when the winding amount of the bobbin thread on the upper part of the bobbin is excessive.
After the adjustment, tighten screw ⑤.
- 7) To adjust the tension of the bobbin winder, turn the thread tension nut ⑦.

(Caution)

1. When winding the bobbin thread, start the winding in the state that the thread between the bobbin and thread tension disk ⑥ is tense.
2. When winding the bobbin thread in the state that sewing is not performed, remove the needle thread from the thread path of thread take-up and remove the bobbin from the hook.
3. There is the possibility that the thread pulled out from the thread stand is loosened due to the influence (direction) of the wind and may be entangled in the handwheel. Be careful of the direction of the wind.

6. Adjusting the height of the knee lifter



WARNING :

Be sure to turn the power OFF before the following work in order to prevent personal injury due to unintentional starting of the sewing machine.

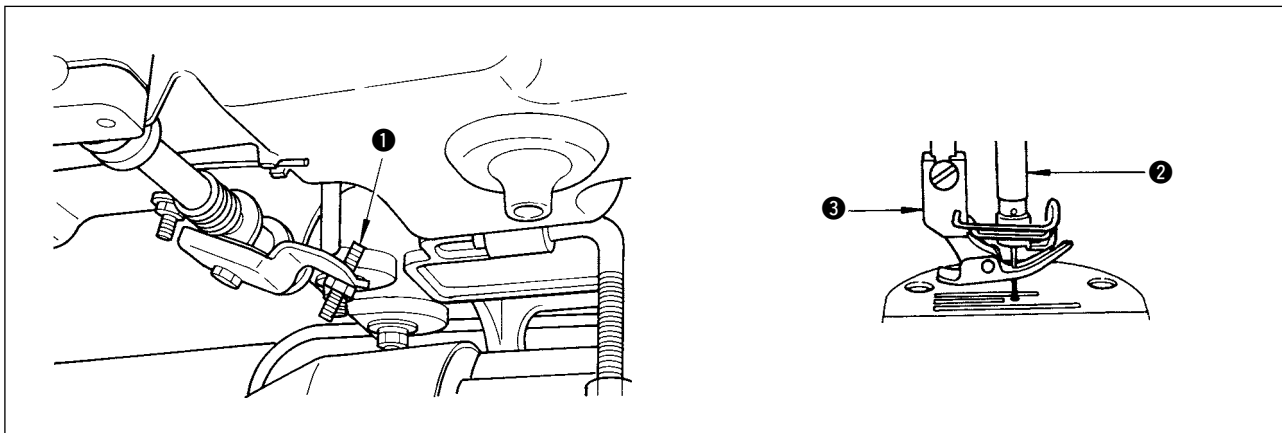

- 1) The standard height of the presser foot lifted using the knee lifter is 10 mm.
- 2) You can adjust the presser foot lift up to 13 mm using knee lifter adjust screw ①.
- 3) When you have adjusted the presser foot lift to over 10 mm, be sure that the bottom end of needle bar ② in its lowest position does not hit presser foot ③.

7. Installing the thread stand

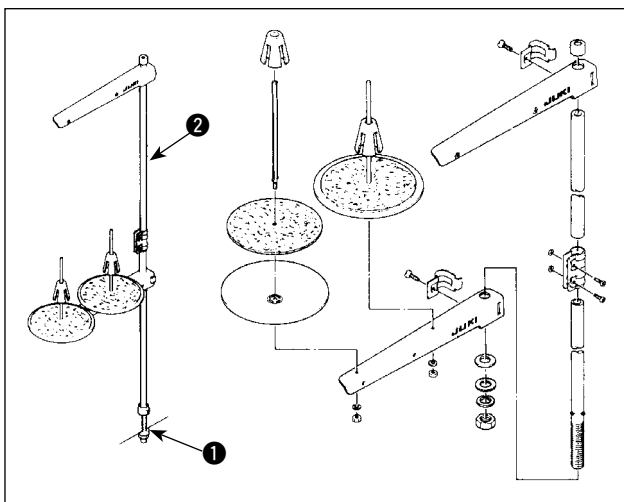

- 1) Assemble the thread stand unit, and insert it in the hole in the machine table.
- 2) Tighten nut ①.
- 3) For ceiling wiring, pass the power cord through spool rest rod ②.

8. Lubrication



WARNING :

1. Do not connect the power plug until the lubrication has been completed so as to prevent accidents due to abrupt start of the sewing machine,
2. To prevent the occurrence of an inflammation or rash, immediately wash the related portions if oil adheres to your eyes or other parts of your body.
3. If oil is mistakenly swallowed, diarrhea or vomiting may occur. Put oil in a place where children cannot reach.

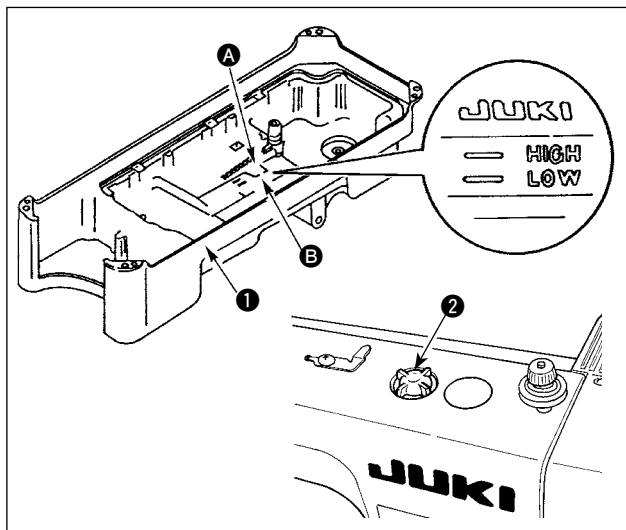

- 1) Before starting the sewing machine, fill oil pan ① with JUKI MACHINE OIL #7 up to HIGH mark ①.
- 2) When the oil level lowers below LOW mark ②, refill the oil pan with the specified oil.
- 3) When you operate the machine after lubrication, you will see splashing oil through oil sight window ② if the lubrication is adequate.
- 4) Note that the amount of the splashing oil is unrelated to the amount of the lubricating oil.



1. When you use a new sewing machine or a sewing machine after an extended period of disuse, use the sewing machine after performing break-in at 2,000 sti/min or less.
2. For the oil for hook lubrication, purchase JUKI NEW DEFRIX OIL No. 1 (Part No. : MD-FRX1600C0) or JUKI MACHINE OIL #7 (Part No. : MML007600CA).
3. Be sure to lubricate clean oil.

9. Adjusting the amount of oil (oil splashes)



WARNING :

Be extremely careful about the operation of the machine since the amount of oil has to be checked by turning the hook at a high speed.

(1) Confirmation of the amount of oil in the hook

① Amount of oil (oil splashes) confirmation paper

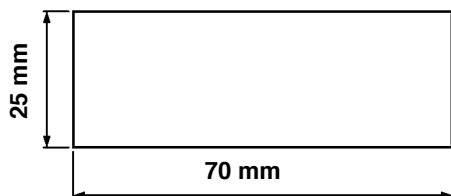

② Position to confirm the amount of oil (oil splashes)

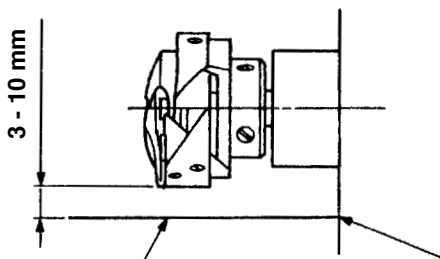

Oil splashes confirmation paper

Closely fit the paper against the wall surface of the bed.

* When carrying out the procedure described below in 2, remove the side plate and take extreme caution not to allow your fingers to come in contact with the hook.

- 1) If the machine has not been sufficiently warmed up for operation, make the machine run idle for approximately three minutes. (Moderate intermittent operation)
- 2) Place the amount of oil (oil spots) confirmation paper under the hook immediately after the machine stops running.
- 3) Confirm the height of the oil surface in the oil reservoir is within the range between "HIGH" and "LOW".
- 4) Confirmation of the amount of oil should be completed in five seconds. (Check the period of time with a watch.)

(2) Adjusting the amount of oil (oil spots) in the hook

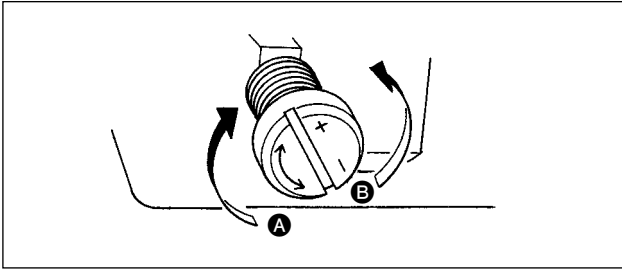

- 1) Turning the oil amount adjustment screw attached on the hook driving shaft front bushing in the “+” direction (in direction **A**) will increase the amount of oil (oil spots) in the hook, or in the “-” direction (in direction **B**) will decrease it.
- 2) After the amount of oil in the hook has been properly adjusted with the oil amount adjustment screw, make the sewing machine run idle for approximately 30 seconds to check the amount of oil in the hook.

(3) Sample showing the appropriate amount of oil in the hook

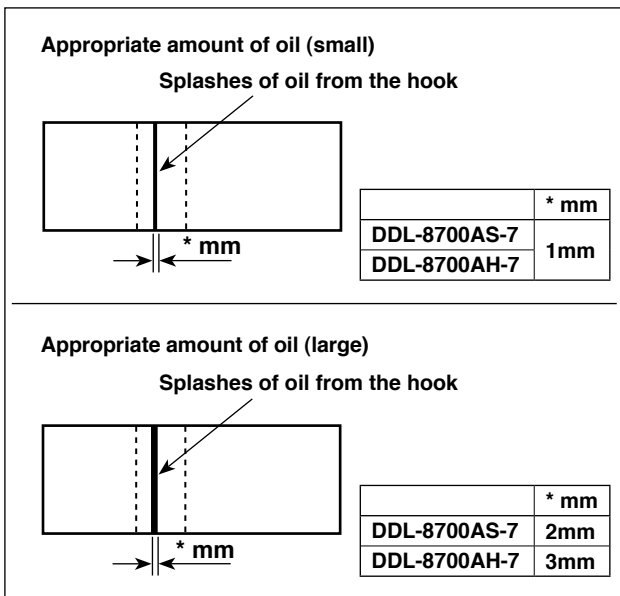

- 1) The amount of oil shown in the samples on the left should be finely adjusted in accordance with sewing processes. Be careful not to excessively increase/decrease the amount of oil in the hook. (If the amount of oil is too small, the hook will be seized (the hook will be hot). If the amount of oil is too much, the sewing product may be stained with oil.)
- 2) Adjust the amount of oil in the hook so that the oil amount (oil splashes) should not change while checking the oil amount three times (on the three sheets of paper).

(4) Confirmation of the amount of oil supplied to the face plate parts

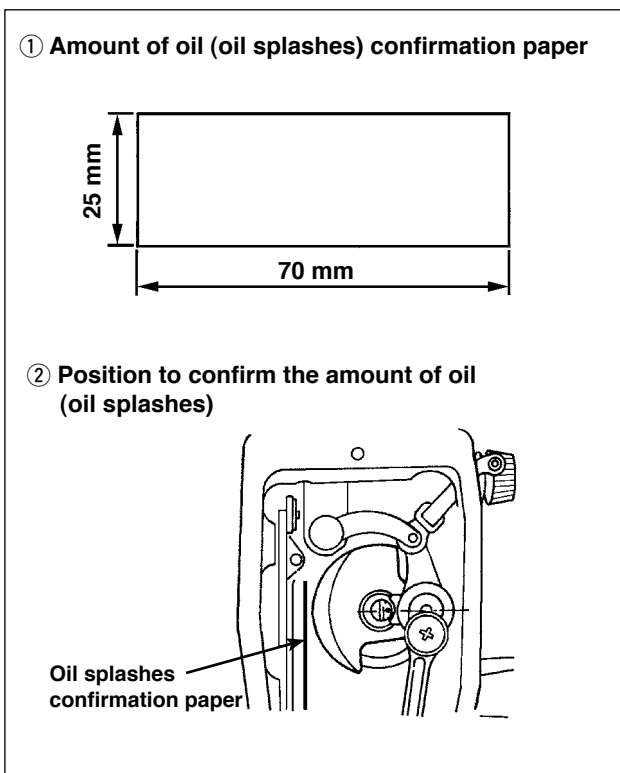

- * When carrying out the work described below in 2), remove the face plate and take extreme caution not to allow your fingers to come in contact with the thread take-up lever.
- 1) If the machine has not been sufficiently warmed up for operation, make the machine run idle for approximately three minutes. (Moderate intermittent operation)
 - 2) Place the amount of oil (oil spots) confirmation paper under the hook immediately after the machine stops running.
 - 3) Confirm the height of the oil surface in the oil reservoir is within the range between “HIGH” and “LOW”.
 - 4) The time required for the confirmation of the amount of oil (oil splashes) should be completed in ten seconds. (Measure the period of time with a watch.)

(5) Adjusting the amount of oil supplied to the face plate parts

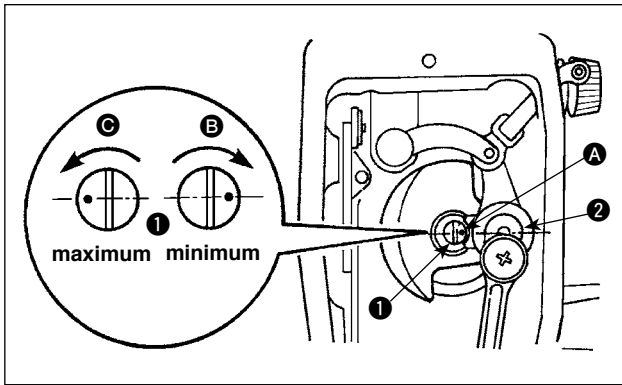

- 1) Adjust the amount of oil supplied to the thread take-up and needle bar crank ② by turning adjust pin ①.
- 2) The minimum amount of oil is reached when marker dot ① is brought close to needle bar crank ② by turning the adjust pin in direction ③.
- 3) The maximum amount of oil is reached when marker dot ① is brought to the position just opposite from the needle bar crank by turning the adjust pin in direction ④.

(6) Sample showing the appropriate amount of oil supplied to the face plate parts

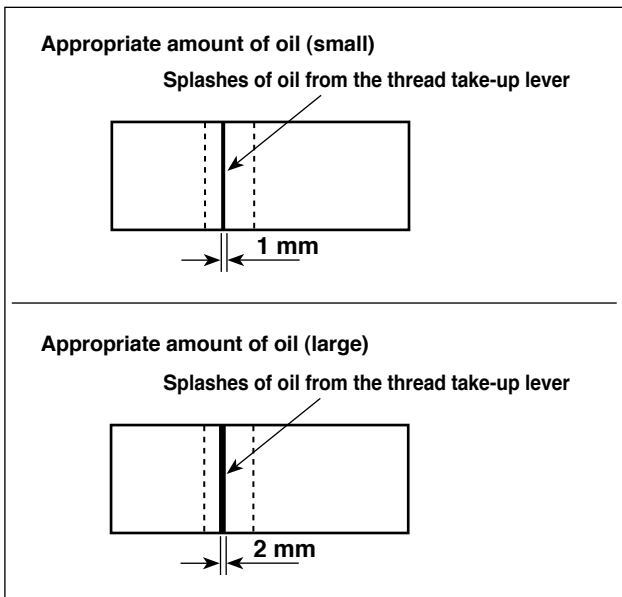

- 1) The state given in the figure shows the appropriate amount of oil (oil splashes). It is necessary to finely adjust the amount of oil in accordance with the sewing processes. However, do not excessively increase/decrease the amount of oil in the hook. (If the amount of oil is too small, the hook will be seized (the hook will be hot). If the amount of oil is too much, the sewing product may be stained with oil.)
- 2) Adjust the amount of oil in the hook so that the oil amount (oil splashes) should not change while checking the oil amount three times (on the three sheets of paper).

10. Attaching the needle



WARNING :

Be sure to turn the power OFF before the following work in order to prevent personal injury due to unintentional starting of the sewing machine.

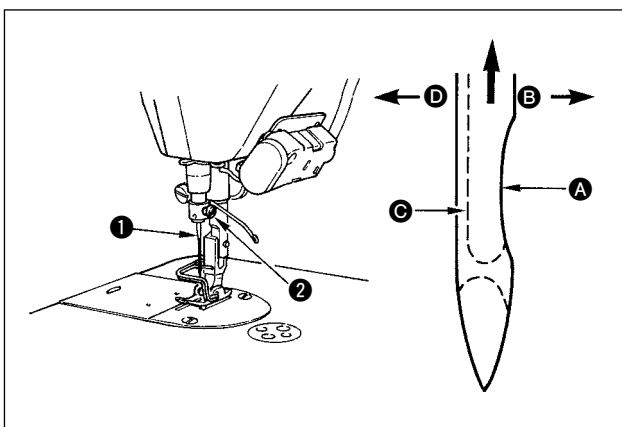

Use the specified needle for the machine. Use the proper needle in accordance with the thickness of thread used and the kinds of the materials.

- 1) Turn the handwheel until the needle bar reaches the highest point of its stroke.
- 2) Loosen screw ②, and hold needle ① with its indented part ① facing exactly to the right in direction ②.
- 3) Insert the needle fully into the hole in the needle bar in the direction of the arrow until the end of hole is reached.
- 4) Securely tighten screw ②.

- 5) Check that long groove ③ of the needle is facing exactly to the left in direction ④.

(Caution) When polyester filament thread is used, if the indented part of the needle is tilted toward operator's side, the loop of thread becomes unstable. As a result, hangnail of thread or thread breakage may occur. For the thread that such phenomenon is likely to occur, it is effective to attach the needle with its indented part slightly slanting on the rear side.

11. Setting the bobbin into the bobbin case

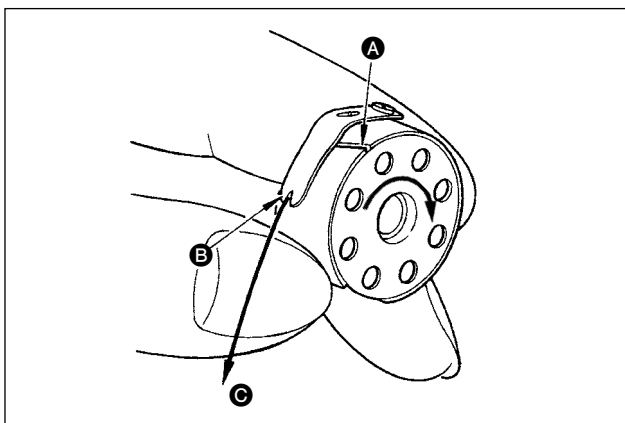

- 1) Pass the thread through thread slit **A**, and pull the thread in direction **C**. By so doing, the thread will pass under the tension spring and come out from notch **B**.
- 2) Check that the bobbin rotates in the direction of the arrow when thread is pulled.

12. Adjusting the stitch length

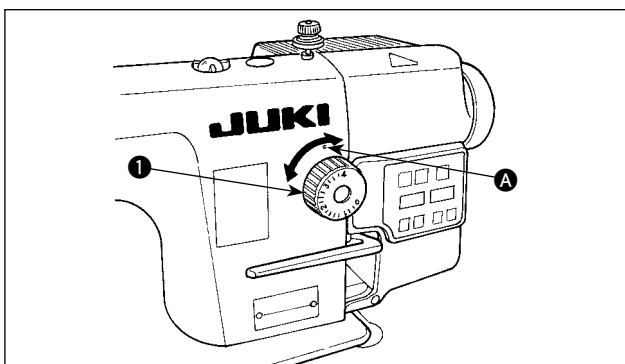

* The dial calibration is in millimeters.

- 1) Turn stitch length dial **1** in the direction of the arrow, and align the desired number to marker dot **A** on the machine arm.

13. Presser foot pressure

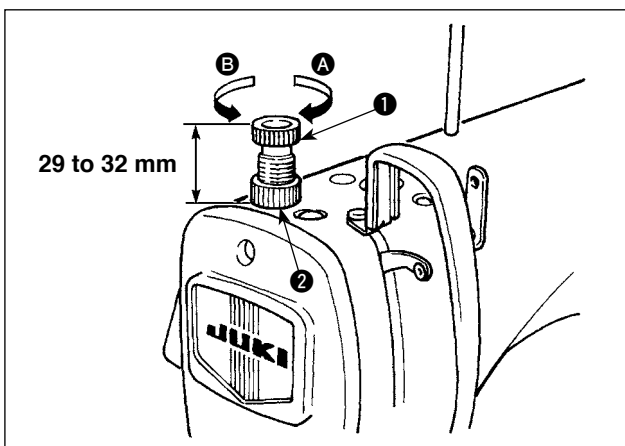

- 1) Loosen nut **2**. As you turn presser spring regulator **1** clockwise (in direction **A**), the presser foot pressure will be increased.
- 2) As you turn the presser spring regulator counter-clockwise (in direction **B**), the pressure will be decreased.
- 3) After adjustment, tighten nut **2**.

The standard value of the pressure regulating thumb screw is 29 to 32 mm.

14. Hand lifter

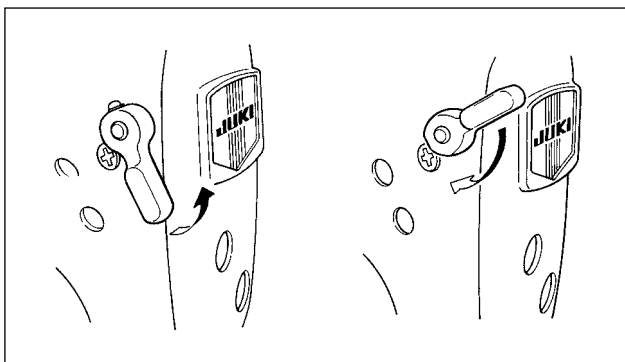

- 1) The presser foot is lifted by moving the lever upward.
- 2) The presser foot is lowered by moving the lever downward.

15. Adjusting the height of the presser bar



WARNING :

Be sure to turn the power OFF before the following work in order to prevent personal injury due to unintentional starting of the sewing machine.

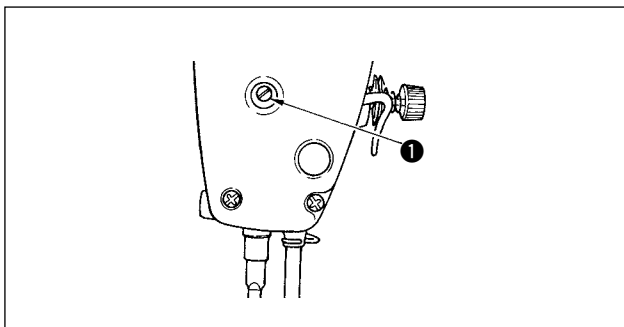

- 1) Loosen setscrew ❶, and adjust the presser bar height or the angle of the presser foot.
- 2) After adjustment, securely tighten the setscrew ❶.

16. Threading the machine head



WARNING :

Be sure to turn the power OFF before the following work in order to prevent personal injury due to unintentional starting of the sewing machine.

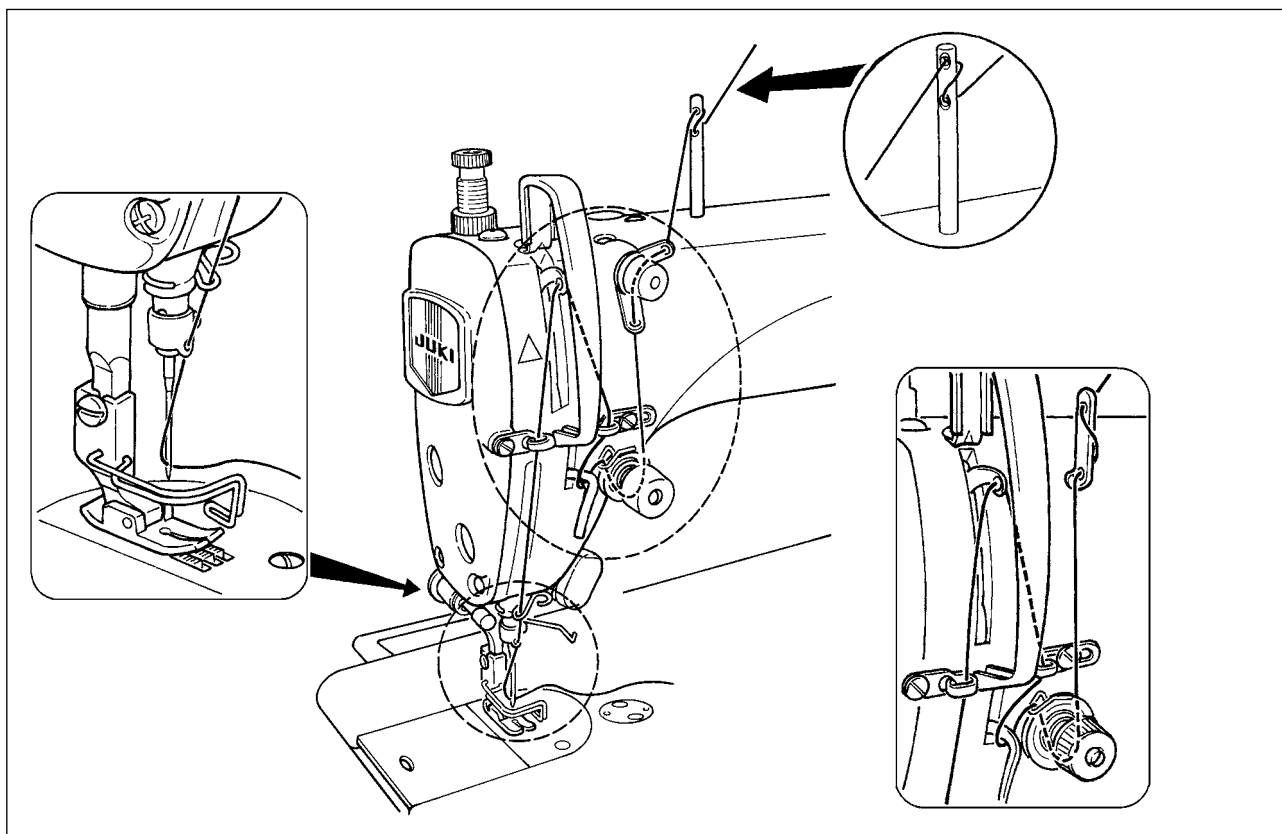

17. Thread tension

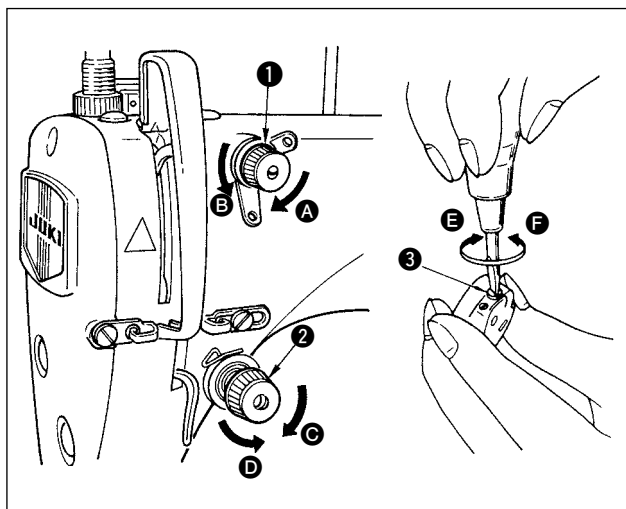

(1) Adjusting the needle thread tension

- 1) The length of thread remaining at the needle tip after thread trimming is shortened by turning tension regulating nut No. 1 **1** clockwise in direction **A**.
- 2) It is lengthened by turning the nut counterclockwise in direction **B**.
- 3) The needle thread tension is increased by turning tension regulating nut No. 2 **2** clockwise in direction **C**.
- 4) It is decreased by turning the nut counterclockwise in direction **D**.

(2) Adjusting the bobbin thread tension

- 1) The bobbin thread tension is increased by turning tension regulating screw **3** clockwise in direction **E**.
- 2) It is decreased by turning the screw counterclockwise in direction **F**.

18. Thread take-up spring

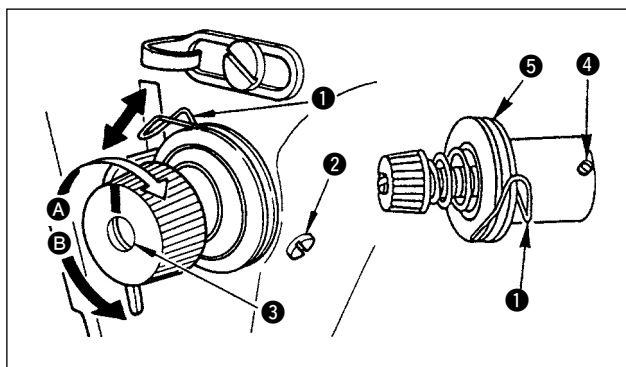

(1) Changing the stroke of thread take-up spring **1**

- 1) Loosen setscrew **2**.
- 2) As you turn tension post **3** clockwise (in direction **A**), the stroke of the thread take-up spring will be increased.
- 3) As you turn the knob counterclockwise (in direction **B**), the stroke will be decreased.

(2) Changing the pressure of thread take-up spring **1**

- 1) Loosen setscrew **2**, and remove tension post **3**.
- 2) Loosen setscrew **4**.
- 3) As you turn tension post **3** clockwise (in direction **A**), the pressure will be increased.
- 4) As you turn the tension post counterclockwise (in direction **B**), the pressure will be decreased.

19. Adjusting the thread take-up stroke



WARNING :

Be sure to turn the power OFF before the following work in order to prevent personal injury due to unintentional starting of the sewing machine.

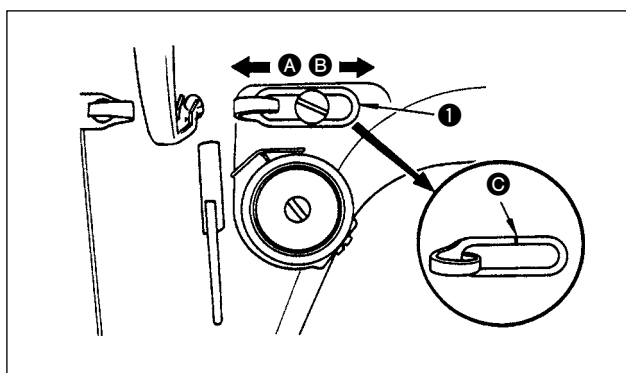

- 1) When sewing heavy-weight materials, move thread guide **1** to the left (in direction **A**) to increase the length of thread pulled out by the thread take-up.
- 2) When sewing light-weight materials, move thread guide **1** to the right (in direction **B**) to decrease the length of thread pulled out by the thread take-up.
- 3) Normally, thread guide **1** is positioned in a way that marker line **C** is aligned with the center of the screw.

20. Needle-to-hook relationship



WARNING :

Be sure to turn the power OFF before the following work in order to prevent personal injury due to unintentional starting of the sewing machine.

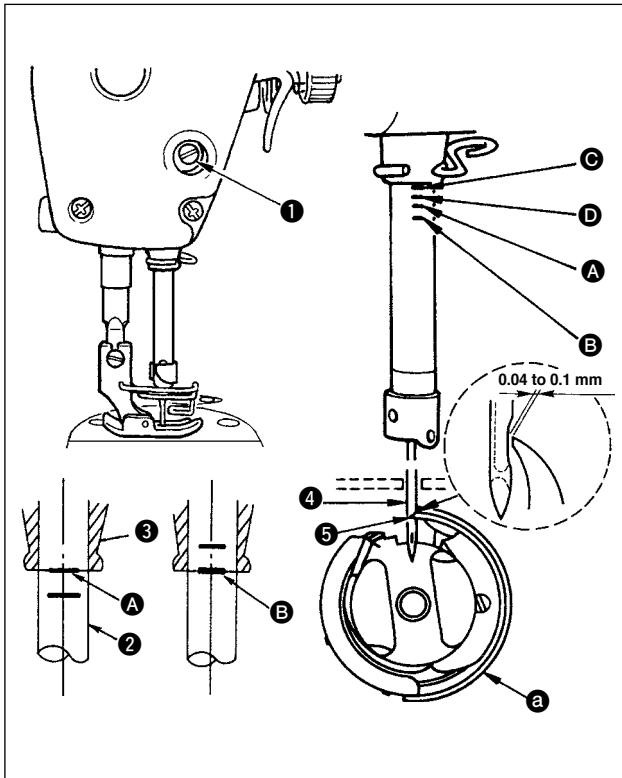

(1) Adjust the timing between the needle and the hook as follows :

- 1) Turn the handwheel to bring the needle bar down to the lowest point of its stroke, and loosen setscrew ①.

(Adjusting the needle bar height)

- 2) (For a DB needle) Align marker line A on needle bar ② with the bottom end of needle bar lower bushing ③, then tighten setscrew ①. (For a DA needle) Align marker line C on needle bar ② with the bottom end of needle bar lower bushing ③, then tighten setscrew ①.

(Adjusting position of the hook ③)

- 3) (For a DB needle) Loosen the three hook setscrews, turn the handwheel and align marker line B on ascending needle bar ② with the bottom end of needle bar lower bushing ③. (For a DA needle) Loosen the three hook setscrews, turn the handwheel and align marker line D on ascending needle bar ② with the bottom end of needle bar lower bushing ③.

- 4) After making the adjustments mentioned in the above steps, align hook blade point ⑤ with the center of needle ④. Provide a clearance of 0.04 mm to 0.1 mm (DDL-8700AH-7 : 0.06 to 0.17mm) (reference value) between the needle and the hook, then securely tighten setscrews in the hook.



If the clearance between the blade point of hook and the needle is smaller than the specified value, the blade point of hook will be damaged. If the clearance is larger, stitch skipping will result.

21. Height of the feed dog



WARNING :

Be sure to turn the power OFF before the following work in order to prevent personal injury due to unintentional starting of the sewing machine.

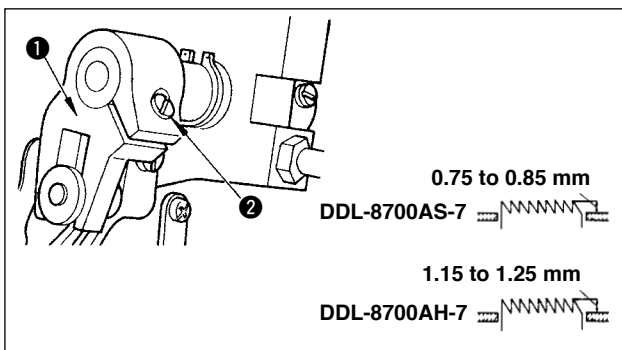

To adjust the height of the feed dog :

- ① Loosen screw ② of crank ①.
- ② Move the feed bar up or down to make adjustment.
- ③ Securely tighten screw ②.



If the clamping pressure is insufficient, the motion of the forked portion becomes heavy.

22. Tilt of the feed dog



WARNING :

Be sure to turn the power OFF before the following work in order to prevent personal injury due to unintentional starting of the sewing machine.

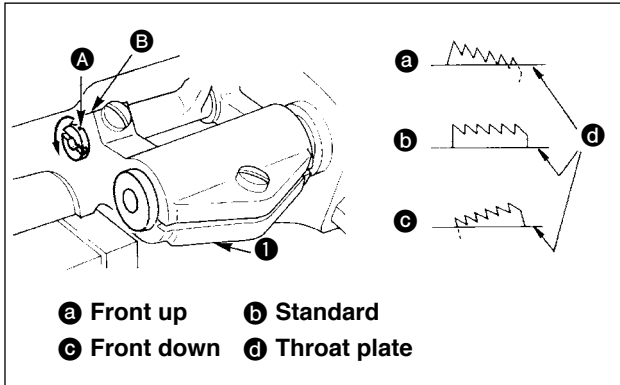

- 1) The standard tilt (horizontal) of the feed dog is obtained when marker dot **A** on the feed bar shaft is aligned with marker dot **B** on feed rocker **1**.
- 2) To tilt the feed dog with its front up in order to prevent puckering, loosen the setscrew, and turn the feed bar shaft 90° in the direction of the arrow, using a screwdriver.
- 3) To tilt the feed dog with its front down in order to prevent uneven material feed, turn the feed bar shaft 90° in the opposite direction from the arrow.



Whenever the feed dog tilt is adjusted, the feed dog height will be changed. So, it is necessary to check the height after tilt adjustment.

23. Adjusting the feed timing



WARNING :

Be sure to turn the power OFF before the following work in order to prevent personal injury due to unintentional starting of the sewing machine.

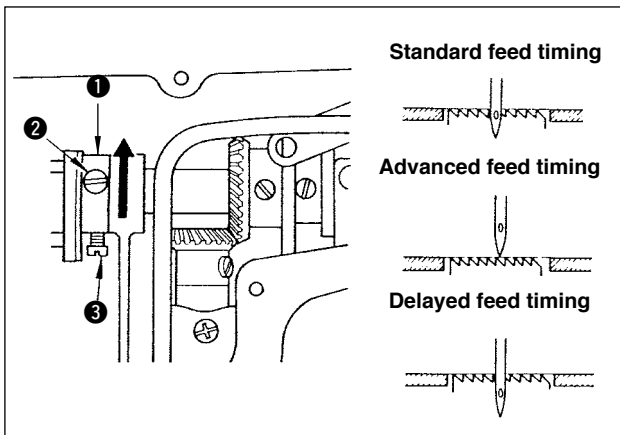

- 1) Loosen screws **2** and **3** in feed eccentric cam **1**, move the feed eccentric cam in the direction of the arrow or opposite direction of the arrow, and firmly tighten the screws.
- 2) For the standard adjustment, adjust so that the top surface of feed dog and the top end of needle eyelet are flush with the top surface of throat plate when the feed dog descends below the throat plate.
- 3) To advance the feed timing in order to prevent uneven material feed, move the feed eccentric cam in the direction of the arrow.
- 4) To delay the feed timing in order to increase stitch tightness, move the feed eccentric cam in the opposite direction from the arrow.



Be careful not to move the feed eccentric cam too far, or else needle breakage may result.

24. Cunter knife



WARNING :

Be sure to turn the power OFF before the following work in order to prevent personal injury due to unintentional starting of the sewing machine.

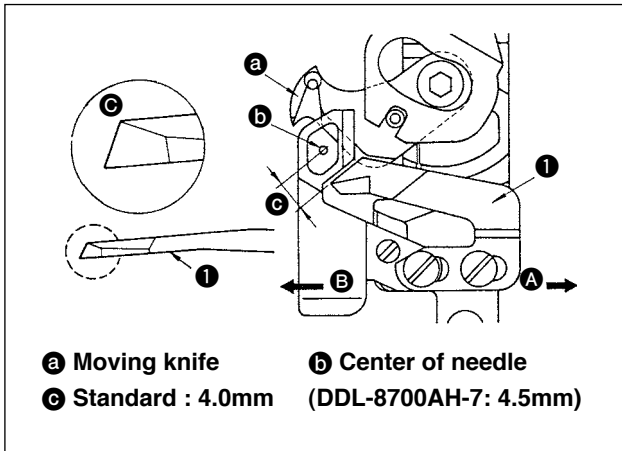

If the knife does not cut thread sharply, immediately re-sharpen counter knife ① as illustrated in Fig. ③ and re-install it properly.

- 1) If the mounting position of the counter knife is moved in direction A from the standard mounting position, the thread length after thread trimming will be increased accordingly.
- 2) If the mounting position is moved in direction B, the thread length will be decreased accordingly.



When sharpening again the knife blade, extra special care must be taken on the handling of the knife.

25. Pedal pressure and pedal stroke



WARNING :

Be sure to turn the power OFF before the following work in order to prevent personal injury due to unintentional starting of the sewing machine.

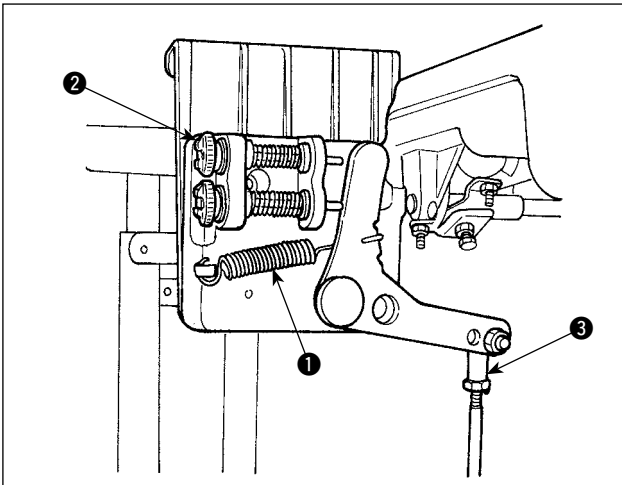

(1) Adjusting the pressure required to depress the front part of the pedal

When the pedal pressure spring ① is hooked to the lower side, the pedal pressure will decrease, and when hooked to the upper side, the pedal pressure will increase.

(2) Adjusting the pressure required to depress the back part of the pedal

The pressure increases as you turn reverse depressing regulator screw ② in, and decreases as you turn the screw out.

(3) Adjusting the pedal stroke

The pedal stroke decreases when you insert connecting rod ③ into the left hole.

26. Adjustment of the pedal



WARNING :

Be sure to turn the power OFF before the following work in order to prevent personal injury due to unintentional starting of the sewing machine.

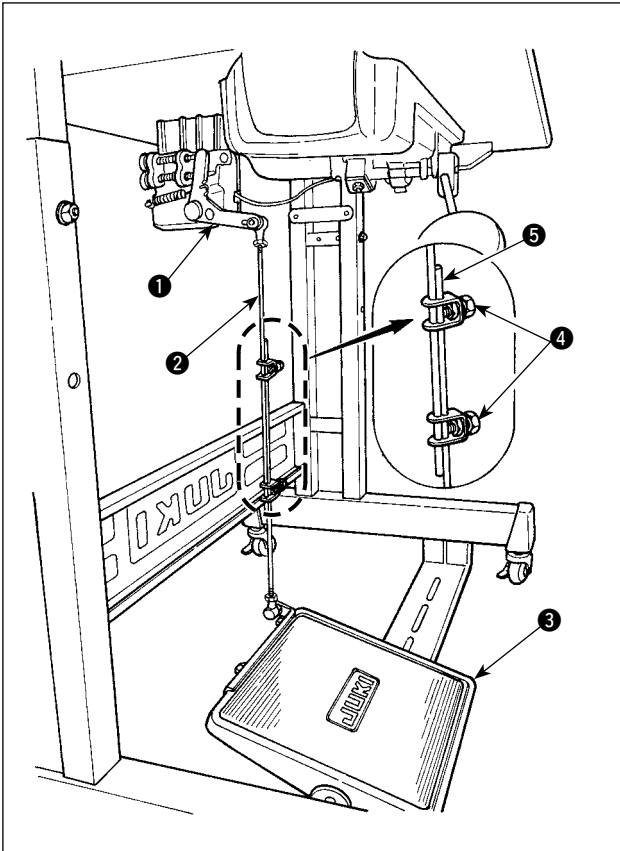

(1) Installing the connecting rod

- 1) Move pedal ③ to the right or left as illustrated by the arrows so that motor control lever ① and connecting rod ② are straightened.

(2) Adjusting the pedal angle

- 1) The pedal tilt can be freely adjusted by changing the length of the connecting rod.
- 2) Loosen adjust screw ④, and adjust the length of connecting rod ②.

III. FOR THE OPERATOR

1. Operating procedure of the sewing machine

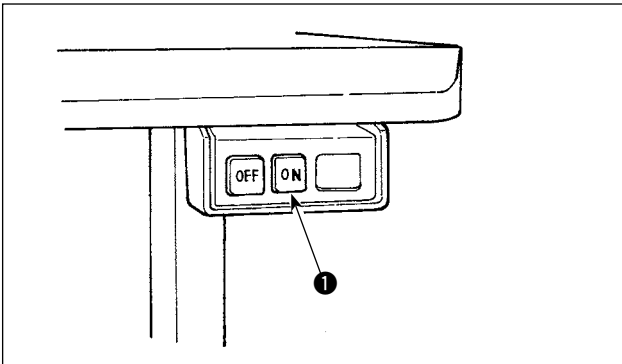

1) Press ON button ❶ of the power switch to turn ON the power.

(Caution) If the backlight of the operation panel does not light up after the power switch is turned ON, immediately turn the power OFF and check the voltage. In addition, in such a case as this, re-turn ON the power switch when 2 to 3 minutes or more have passed after turning OFF the power switch.

2) When the needle bar is not in UP position, it automatically turns to the UP position.

(Caution) When turning ON the power for the first time, there is the case where the timing is slightly retarded to perform the initialization work. When turning ON the power, the needle bar moves. Do not put your hands or things under the needle.

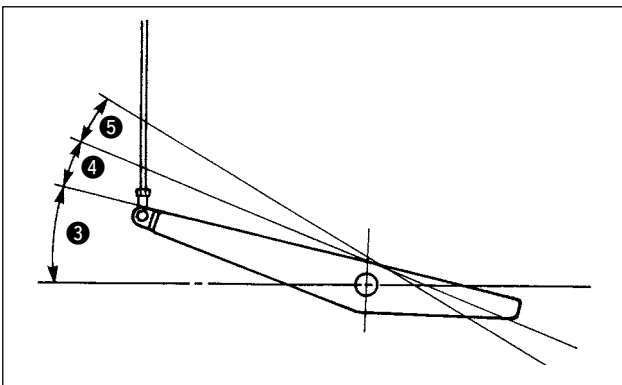

3) The pedal is operated in the following four steps:

a. The machine runs at low sewing speed when you lightly depress the front part of the pedal. ❸

b. The machine runs at high sewing speed when you further depress the front part of the pedal. ❸
(If the automatic reverse feed stitching has been preset, the machine runs at high speed after it completes reverse feed stitching.)

c. The machine stops (with its needle up or down) when you reset the pedal to its original position.

d. The machine trims threads when you fully depress the back part of the pedal. ❹

- * When the auto-lifter (AK device) is used, one more operating switch is provided between the sewing machine stop switch and thread trimming switch. The presser foot goes up when you lightly depress the back part of the pedal ❹, and if you further depress the back part ❺, the thread trimmer is actuated. When starting sewing from the state that the presser foot has been lifted with the Auto-lifter and you depress the back part of the pedal, the presser foot only comes down.
- If you reset the pedal to its neutral position during the automatic reverse feed stitching at seam start, the machine stops after it completes the reverse feed stitching.
- The machine will perform normal thread trimming even if you depress the back part of the pedal immediately following high or low speed sewing.
- The machine will completely perform thread trimming even if you reset the pedal to its neutral position immediately after the machine started thread trimming action.

	PFL	KFL
Presser foot operation by pedal	Enabled	Disabled
Pedal depressing depth for thread trimming	Deep	Shallow

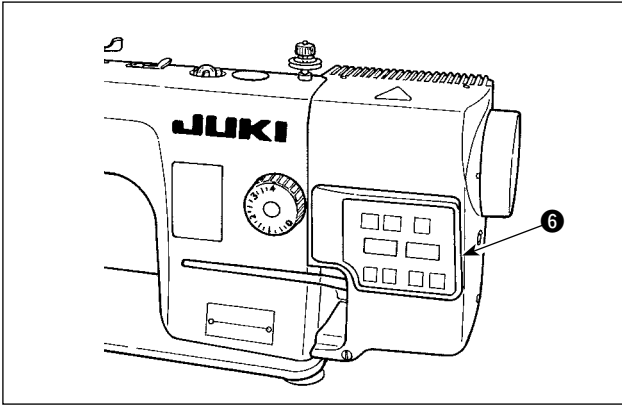

4) Reverse feed stitching at the beginning of sewing, reverse feed stitching at the end of sewing and various sewing patterns can be set on built-in panel ⑥ of the machine head.

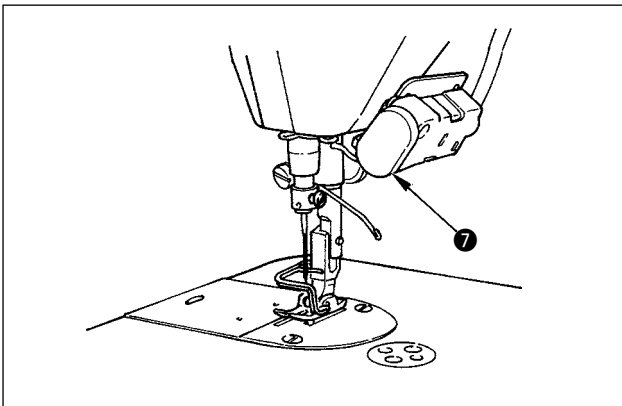

5) For some types of the sewing machine heads, reverse feed is performed by pressing touch-back switch ⑦.

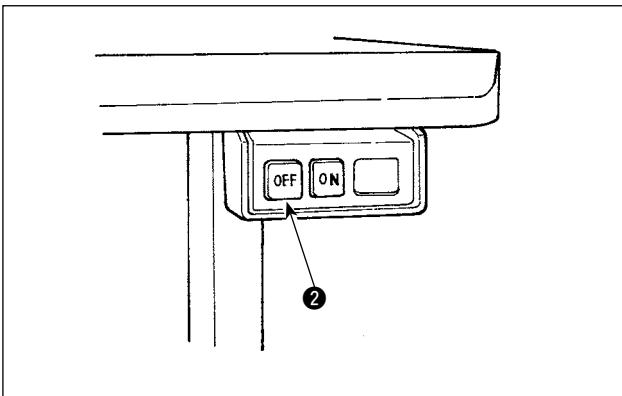

6) When sewing is completed, press OFF button ② of the power switch to turn OFF the power switch after confirming that the sewing machine has stopped.

(Caution) In the case the machine is not used for a long time, remove the power plug from the plug receptacle.

2. Built-in panel of the machine head

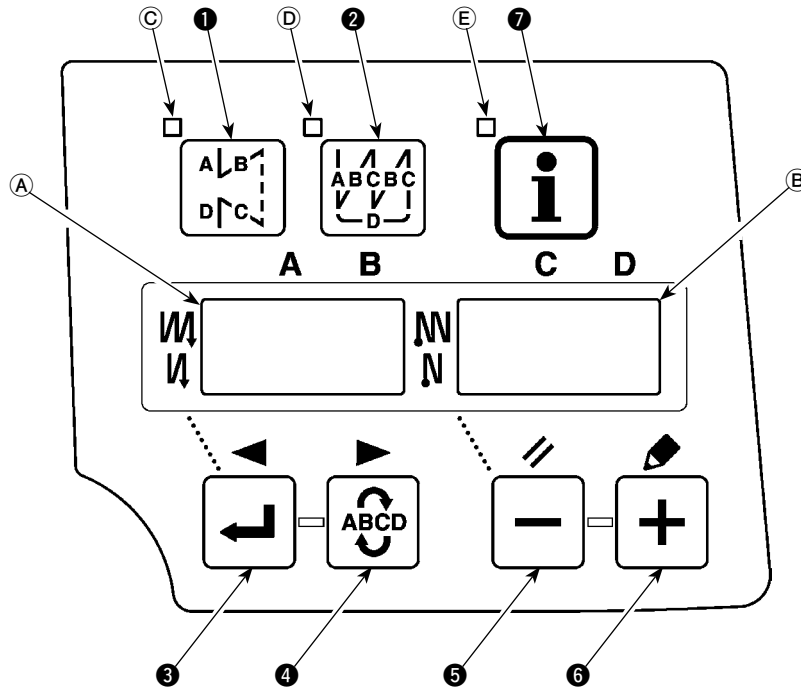

- ① switch : Used for changing over effective/ineffective of the reverse feed stitching pattern.
- ② switch : Used for changing over effective/ineffective of the overlapped stitching pattern.
- ③ switch : Used for confirming the contents of setting and for changing over effective/ineffective of the reverse feed stitching at sewing start.
- ④ switch : Used for selecting the process (A, B, C, D) the number of stitches for which is to be changed.
* The selected process flashes on and off.
- ⑤ switch : Used for changing the content of the selected display (flashing section) and for changing over effective/ineffective of the reverse stitch at sewing end.
- ⑥ switch : Used for changing the content of the selected display (flashing section).
- ⑦ switch : It is used to call the production support function and to call the one-touch setting (it should be held pressed for one second).

Indicators ① and ② : Various pieces of information are displayed.

LED ③ : Lights up when the reverse feed stitching pattern is effective.

LED ④ : Lights up when the overlapped stitching pattern is effective.

LED ⑤ : Lights up when the production support function is displayed.

3. Operating procedure of the sewing pattern

(Caution) Refer to the Instruction Manual for each operation panel for how to operate sewing patterns using other operation panel than the built-in panel of the machine head.

(1) Reverse feed stitching pattern

Reverse feed stitching at sewing start and reverse feed stitching at sewing end can be separately programmed.

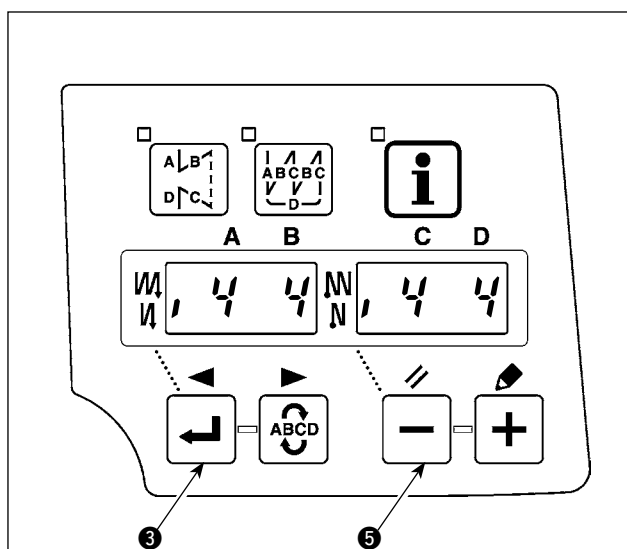
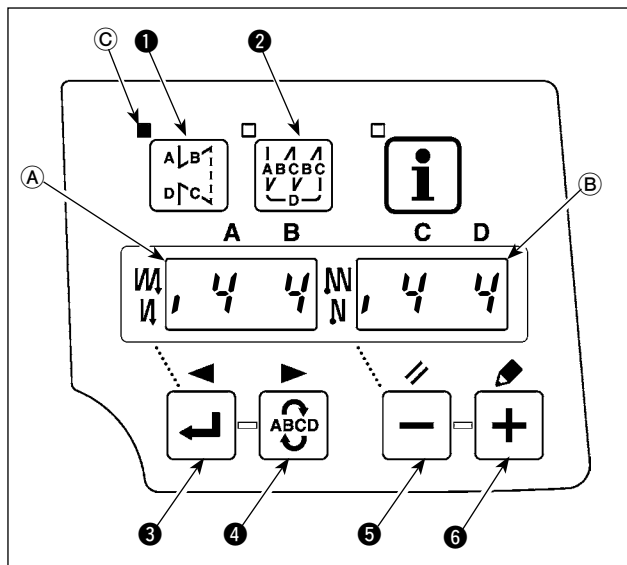

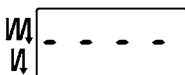
Without reverse stitching 

Reverse stitching 

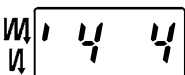

Double reverse stitching 

[Setting procedure of the reverse feed stitching]

1) Effective/ineffective of the reverse feed stitching pattern can be changed over by pressing  switch ①.

When the reverse feed stitching pattern is rendered effective, LED ③ lights up, the number of stitches of the reverse feed stitching at sewing start is displayed on ④, and the number of stitches of the reverse feed stitching at sewing end is displayed on indicator ⑤.

Select a process (A, B, C or D) the number of stitches for which is to be changed by using  switch ④.

The number which is flashing on and off represents the process which is being set. Change the number of stitches for the selected process by using  switch ⑤ and  switch ⑥.

Press  switch ③ to confirm the change you have made. (The number of stitches that can be set is 0 to 15.)

⑥.

(Caution) The sewing machine cannot perform sewing when the display of the number of stitches for a process is flashing on and off.

2) When the number of reverse feed stitches display is not flashing on and off, every press on  switch ③ changes over the reverse feed stitching mode from the "reverse feed stitching at sewing start," "double reverse feed stitching at sewing start" and "no reverse feed stitching at sewing start."

In addition, every time  switch ⑤ is pressed, the reverse feed stitching feature changes over from the reverse feed stitching at sewing end to the double reverse stitch at sewing end, then to no reverse feed stitching at sewing end, in turn.

(2) Overlapped stitching pattern

Overlapped stitching pattern can be programmed.

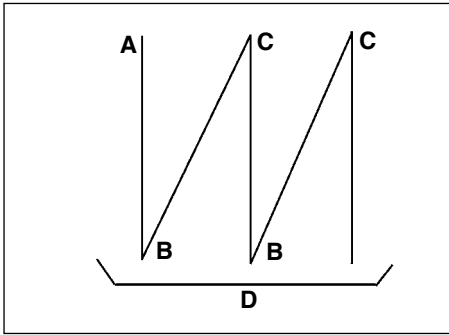



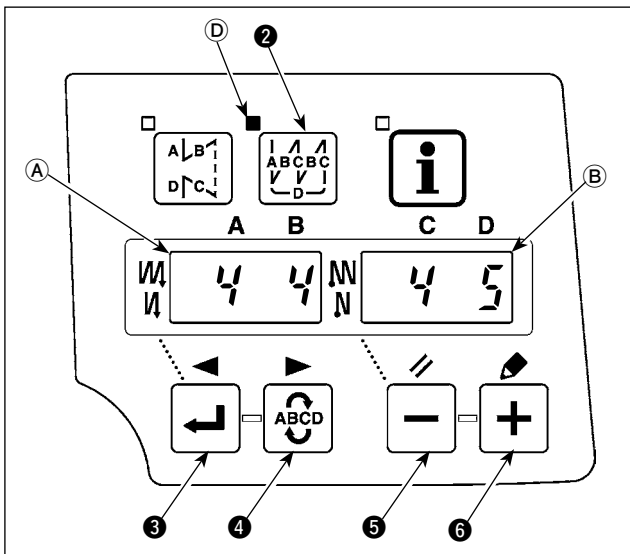

- A : Number of stitches of normal stitching setting
0 to 15 stitches
- B : Number of stitches of reverse stitching setting
0 to 15 stitches
- C : Number of stitches of normal stitching setting
0 to 15 stitches
- D : Number of times of repetition
0 to 9 times

(Caution) When process D is set to 5 times, the sewing is repeated as A → B → C → B → C.



[Setting procedure of the overlapped stitching]

- 1) Effective/ineffective of the overlapped stitching pattern can be changed over by pressing  switch **1**.
When the overlapped stitching pattern is rendered effective, LED **①** lights up.
- 2) Select a process (A, B, C or D) the number of stitches for which is to be changed by using  switch **2**.
The number which is flashing on and off represents the process which is being set.

3) Change the number of stitches for the selected process by using  switch **5** and  switch **6**.

4) Press  switch **3** to confirm the change you have made.

(The sewing machine does not run unless the setting has been confirmed by pressing  switch **3**.)

(Caution) The overlapped stitching pattern is carried out under automatic operation mode. Once the pedal is depressed, the sewing machine will automatically perform sewing of the number of overlapped stitches.

4. One-touch setting

A part of function setting items can be easily changed in the normal sewing state.

(Caution) For the setting of functions other than those covered in this part, refer to "III-6. Setting of functions" p. 28.

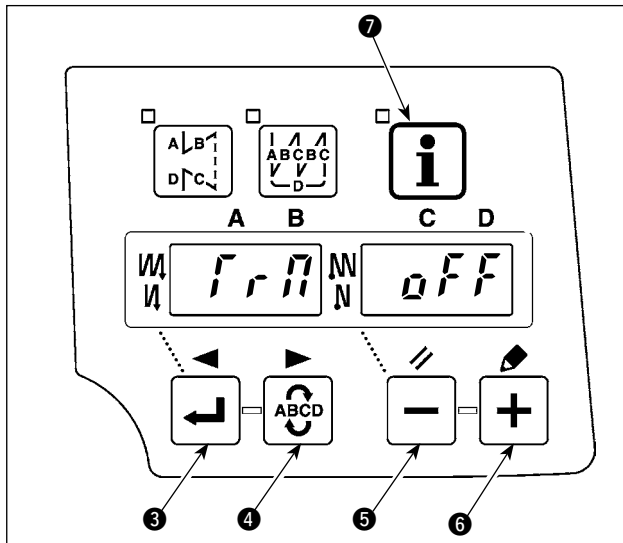

[One-touch setting procedure]

- 1) Keep **i** switch ⑦ held pressed for one second to place the panel in the function setting mode.
- 2) Change over the item to be set by using **←** switch ③ or **ABCD** switch ④. Then, the set value can be changed by using **-** switch ⑤ and **+** switch ⑥.
- 3) To return to the normal sewing state, press **i** switch ⑦.

(Caution) The setting is confirmed by pressing **i** switch ⑦. One-shot automatic sewing, material edge sensor, thread trimming by the material edge sensor and the number of stitches of the material edge sensor are not displayed in the default setting at the time of delivery.

- ① Thread trimming function (*Trn*)
FFF : Thread trimming operation is not performed (solenoid output prohibition: Thread trimmer, wiper)
nn : Thread trimming operation is effective.
- ② Wiper function (*Wp*)
FFF : Wiper does not operate after thread trimming. *nn* : Wiper operates after thread trimming
- ③ One-shot automatic stitching function (*Shof*)
FFF : One-shot automatic stitching function is ineffective. *nn* : One-shot automatic stitching is effective.

(Caution) This function is rendered effective when the material end sensor function is set. It is not possible to prohibit the one-shot operation during overlapped sewing operation. The number of revolution is the value which is set for setting No. 38.

- ④ Setting of the max. speed of stitch (*Spd*)
 The highest speed of stitch of the machine head is set. The upper limit of the set value differs with the type of machine head to which the SC is connected.
 Setting range : 150 - Max. value [sti/min]
- ⑤ Material end sensor function (*Ed*)
FFF : Material end sensor function is ineffective.
nn : Once the material end is detected, the sewing machine stops running after having sewn the number of stitches set with ⑦ (*Edsr*).
 * This function is rendered effective when the material edge sensor is set with function setting No. 12.
- ⑥ Thread trimming function by material end sensor (*EdTr*)
FFF : Automatic thread trimming function after the detection of material end is ineffective.
nn : Once the material end is detected, the sewing machine performs thread trimming after having sewn the number of stitches set with ⑦ (*Edsr*).
 * This function is rendered effective when the material edge sensor is set with function setting No. 12.
- ⑦ Number of stitches for material end sensor (*Edsr*)
 The number of stitches to be sewn from the detection of material end to the stop of the sewing machine
 Number of stitches that can be set: 0 to 19 (stitches)

(Caution) This function is rendered effective when the material end sensor function is set. If the number of stitches specified is inadequate, the sewing machine can fail to stop within the preset number of stitches depending on the number of revolutions of the sewing machine.

- ⑧ Adjustment of quantity of light of LED light (*Lamp*)
 The quantity of light of the LED light is adjusted
 Setting range : 0 to 100

5. Production support function

The production support function consists of three different functions (six different modes) such as the production volume management function, operation measuring function and bobbin counter function. Each of them has its own production support effect. Select the appropriate function (mode) as required.

■ Production volume management function

Target No. of pcs. display mode [F100]

Target/actual No. of pcs difference display mode [F200]

The target number of pieces, actual number of pieces and the difference between the target and actual number of pieces along with the operation time are displayed to notify the operators of a delay and advance in real time. Sewing machine operators are allowed to engage sewing while constantly checking his/her work pace. This helps raise target awareness, thereby increasing productivity. In addition, a delay in work can be found at an early stage to enable early detection of problems and early implementation of corrective measures.

■ Operation measuring function

Sewing machine availability rate display mode [F300]

Pitch time display mode [F400]

Average number of revolutions display mode [F500]

Sewing machine availability status is automatically measured and displayed on the control panel. The data obtained can be used as basic data to perform process analyses, line arrangement and equipment efficiency checkup.

■ Bobbin counter function

Bobbin counter display mode

In order to change bobbins before the current bobbin runs out of thread, the time for replacing the bobbin is notified.

[To use the production support mode]

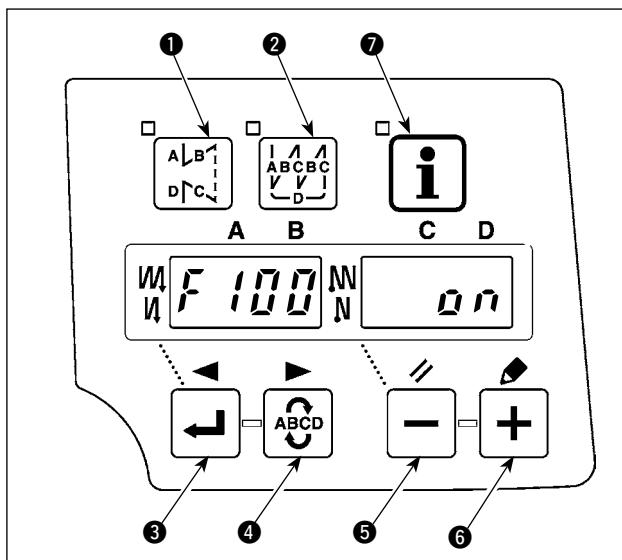

(Caution) Modes F100 to F500 have been factory-set in the OFF state at the time of delivery. The mode state is changed over to ON/OFF according to the setting of the bobbin thread counter function (function setting No. 6).

Keep **i** switch **7** held pressed (one second) in the normal sewing state to call the one-touch setting screen.

Then, press **A/B** switch **1** or **A/B/C/D** switch **2** to set each production support mode in ON/OFF state to call the one-touch setting screen.

Press **←** switch **3** or **ABCD** switch **4** to select the mode to be set in the ON/OFF state.

ON/OFF of the display can be changed over by pressing **-** switch **5** or **+** switch **6**.

To return to the normal sewing state, press **i** switch **7**.

Sewing can be performed with the production support data displayed on the control panel.

[Basic operation of the production support modes]

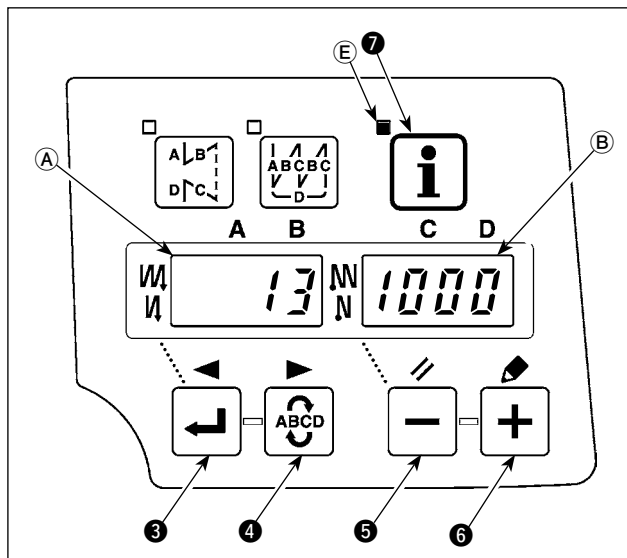

- 1) When **i** switch 7 is pressed in the normal sewing state, LED E lights up to enter the production support mode.
- 2) Production support function can be changed over by pressing **←** switch 3 or **↻** switch 4.
- 3) Data attached marked with (*1) in Table 1 "Indicator A" can be changed by means of **-** switch 5 and **+** switch 6.

- 4) When you keep **+** switch 6 held pressed for two seconds, indicator B and LED E flash on and off. While they are flashing on and off, data marked with (*2) in Table 1 "Display under modes" can be changed by pressing **-** switch 5 and **+** switch 6.

When you press **i** switch 7, the value marked with (*2) is confirmed and indicator B and LED E stop flashing on and off.

- 5) The value with a sharp mark (*3) in Table 1 "Display of modes" can be changed only immediately after resetting by using **-** switch 5 and **+** switch 6.
- 6) Refer to the table "Mode resetting operation," for the resetting procedure of data.
- 7) To return to the normal sewing state, press **i** switch 7.

Data to be displayed under the respective modes are as described in the table below.

Table 1: Display of modes

Mode name	Indicator A	Indicator B	Indicator B (when - switch 5 is pressed)
Target No. of pcs. display mode (F100)	Actual number of pieces (Unit : piece) (*1)	Target number of pieces (Unit : piece) (*2)	-
Target/actual No. of pcs. difference display mode [F200]	Difference between target number of pieces and actual number of pieces (d : piece) (*1)	Target pitch time (Unit : 100 msec) (*2)	-
Sewing machine availability rate display mode (F300)	oP-r	Sewing machine availability rate in the previous sewing (Unit : %)	Display of average availability rate of sewing machine (Unit : %)
Pitch time display mode (F400)	Pi-T	Pitch time in the previous sewing (Unit : 1sec)	Display of average pitch time (Unit : 100 msec)
Average number of revolutions display mode (F500)	ASPd	Average number of revolutions in the previous sewing (Unit : sti/min)	Display of average number of revolutions (Unit : sti/min)
Bobbin counter display mode	bbn	Bobbin counter value (*3)	-

Table 2: Mode resetting operation

Mode name	<input type="checkbox"/> Switch ⑤ (held pressed for 2 seconds)	<input type="checkbox"/> Switch ⑤ (held pressed for 4 seconds)
Target No. of pcs. display mode (F100)	Resets the actual number of pieces Resets the difference between target number of pieces and actual number of pieces	-
Target/actual No. of pcs. difference display mode (F200)	Resets the actual number of pieces Resets the difference between target number of pieces and actual number of pieces	-
Sewing machine availability rate display mode (F300)	Resets average availability rate of sewing machine	Resets average availability rate of sewing machine. Resets average pitch time. Resets average number of revolutions of sewing machine.
Pitch time display mode (F400)	Resets average pitch time	Resets average availability rate of sewing machine. Resets average pitch time. Resets average number of revolutions of sewing machine.
Average number of revolutions display mode (F500)	Resets average number of revolutions of sewing machine.	Resets average availability rate of sewing machine. Resets average pitch time. Resets average number of revolutions of sewing machine.
Bobbin counter display mode	Resets the bobbin counter value (Note that only the bobbin counter is immediately reset by pressing <input type="checkbox"/> switch ⑤.)	-

[Detailed setting of production volume management function (F101, F102)]

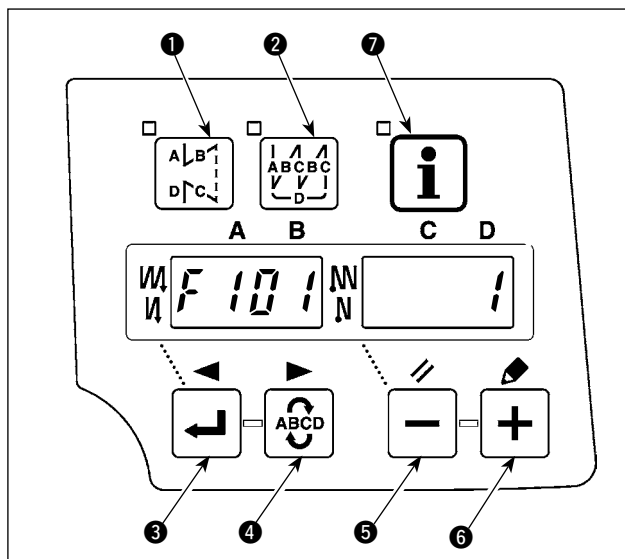

When switch ⑦ is held pressed (for three seconds) under the target No. of pcs. display mode (F100) or the target/actual No. of pcs. difference display mode (F200), the detailed setting of the production volume management function can be carried out.

The setting state of the number of times of thread trimming (F101) and that of the target achievement buzzer (F102) can be changed over by pressing switch ③ or switch ④.

The number of times of thread trimming for sewing one piece of garment can be set by pressing switch ⑤ or switch ⑥ in the setting state of the number of times of thread trimming (F101).

It is possible to set whether the buzzer sounds or not when the actual number of pieces has reached the target volume by pressing switch ⑤ or switch ⑥ in the setting state of the target achievement buzzer (F102).

6. Setting of functions

Functions can be selected and specified.

(Caution) Refer to the Instruction Manual for each operation panel for how to operate sewing patterns using other operation panel than the built-in panel of the machine head.

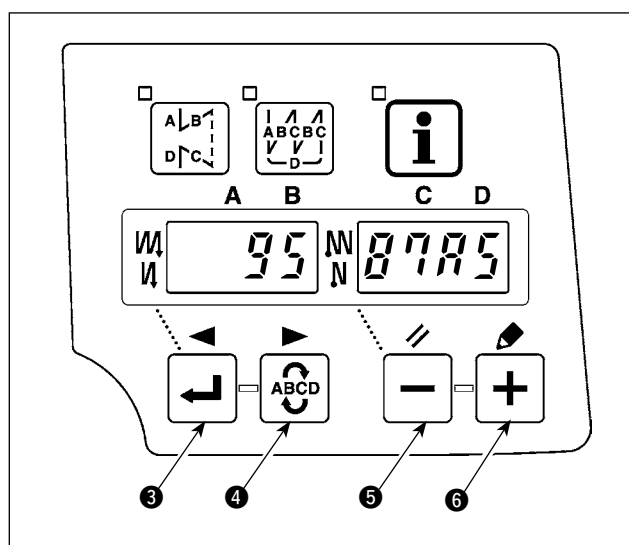
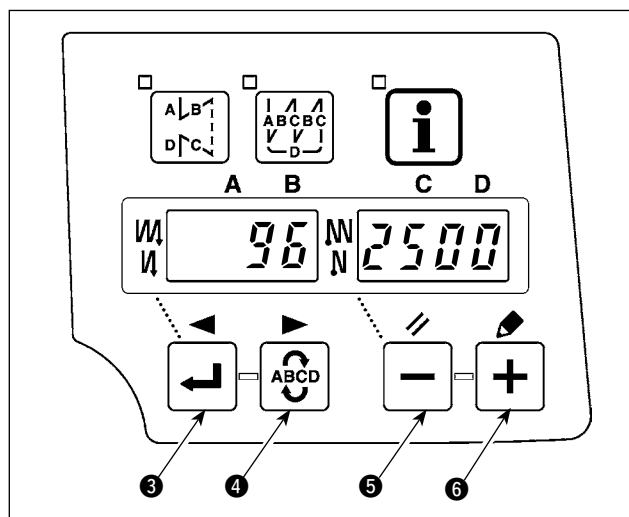
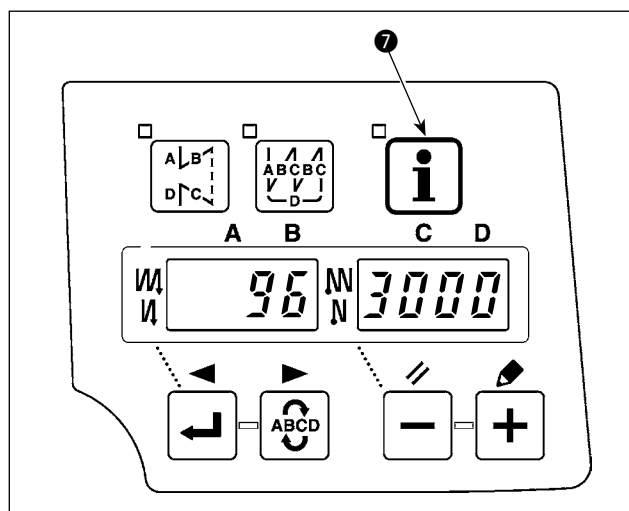

setting No. When  switch ④ is pressed, the display on the panel changes to the subsequent setting No. After completion of the operation, the machine is returned to the normal sewing state by turning OFF the power and re-turning it ON.

1) Turn ON the power with  switch ⑦ held pressed.



(The item which has been changed during the previous work is displayed.)

* If the screen display does not change, re-carry out operation described in step 1).



(Caution) Be sure to re-return ON the power switch when one or more seconds have passed after turning it OFF. If the power switch is re-turned ON immediately after turning it OFF, the sewing machine may fail to operate normally. In such a case, be sure to turn ON the power switch again properly.

2) To move the setting No. forward, press  switch ④. To move the setting No. backward,

press  switch ③.



(Caution) If the setting No. is moved forward (or backward), the previous (or subsequent) content of the setting is confirmed. Be careful when the content of a setting is changed (when the  /  switch is touched).



Example) Changing the maximum number of revolutions (setting No. 96)

Press  switch ③ or  switch ④ to call setting No. "96."

The current set value is displayed on indicator ②.

Press  switch ⑤ to change the setting to "2500."

* The content of setting of the setting No. returns to the initial value by pressing  switch ⑤ and  switch ⑥ simultaneously.

3) After completion of the changing procedure, press  switch ③ or  switch ④ to confirm the updated value.

(Caution) If the power is turned OFF before carrying out this procedure, the changed content is not updated. When  switch ③ is pressed, the display on the panel changes to the previous

7. Function setting list

No.	Item	Description	Setting range	Indication of function setting	Ref. page
1	Soft start function	The number of stitches to be sewn at a low speed when the soft-start function is used at the start of sewing. 0 : The function is not selected. 1 to 9 : The number of stitches to be sewn under the soft-start mode.	0 to 9 (Stitches)	<input type="text" value=""/> <input type="text" value=""/> <input type="text" value=""/> <input type="text" value="1"/> <input type="text" value=""/> <input type="text" value=""/> <input type="text" value="0"/>	33
2	Material end sensor function	Material end sensor function. 0 : Material end detection function is not operative. 1 : After detecting material end, the specified number of stitches (No. 4) will be sewn, and the sewing machine will stop.	0/1	<input type="text" value=""/> <input type="text" value=""/> <input type="text" value=""/> <input type="text" value="2"/> <input type="text" value=""/> <input type="text" value=""/> <input type="text" value="0"/>	33
3	Thread trimming function by material end sensor	Thread trimming function by material end sensor. 0 : Automatic thread trimming function after detection of material end is not operative. 1 : After detecting material end, the specified number of stitches (No. 4) will be sewn, and the sewing machine will stop and perform automatic thread trimming.	0/1	<input type="text" value=""/> <input type="text" value=""/> <input type="text" value=""/> <input type="text" value="3"/> <input type="text" value=""/> <input type="text" value=""/> <input type="text" value="0"/>	33
4	Number of stitches for material end sensor	Number of stitches for material end sensor. Number of stitches from detection of material end to stop of the sewing machine.	0 to 19 (Stitches)	<input type="text" value=""/> <input type="text" value=""/> <input type="text" value=""/> <input type="text" value="4"/> <input type="text" value=""/> <input type="text" value=""/> <input type="text" value="5"/>	33
5	Flicker reducing function	Flicker reducing function 0 : Flicker reducing function is not operative. 1 : Flicker reducing function is effective	0/1	<input type="text" value=""/> <input type="text" value=""/> <input type="text" value=""/> <input type="text" value="5"/> <input type="text" value=""/> <input type="text" value=""/> <input type="text" value="0"/>	33
6	Bobbin thread counting function	Bobbin thread counting function 0 : Bobbin thread counting function is not operative. 1 : Bobbin thread counting function is operative.	0/1	<input type="text" value=""/> <input type="text" value=""/> <input type="text" value=""/> <input type="text" value="6"/> <input type="text" value=""/> <input type="text" value=""/> <input type="text" value="1"/>	33
* 7	Unit of bobbin thread counting down	Unit of bobbin thread counting down 0 : 1 Count/10 stitches 1 : 1 Count/15 stitches 2 : 1 Count/20 stitches 3 : 1 Count/thread trimming	0 to 3	<input type="text" value=""/> <input type="text" value=""/> <input type="text" value=""/> <input type="text" value="7"/> <input type="text" value=""/> <input type="text" value=""/> <input type="text" value="0"/>	
* 8	Number of rotation of reverse feed stitching	Sewing speed of reverse feed stitching	150 to 3,000 (sti/min)	<input type="text" value=""/> <input type="text" value=""/> <input type="text" value=""/> <input type="text" value="8"/> <input type="text" value=""/> <input type="text" value="1"/> <input type="text" value="9"/> <input type="text" value="0"/> <input type="text" value="0"/>	
9	Thread trimming prohibiting function	Thread trimming prohibiting function. 0 : Thread trimming is effective. 1 : Thread trimming is prohibited. (Output of solenoid is prohibited. : Thread trimmer and wiper)	0/1	<input type="text" value=""/> <input type="text" value=""/> <input type="text" value=""/> <input type="text" value="9"/> <input type="text" value=""/> <input type="text" value=""/> <input type="text" value="0"/>	33
10	Setting of needle bar stop position when the sewing machine stops.	Position of needle bar is specified when the sewing machine stops. 0: The needle bar stops at its lower position. 1: The needle bar stops at its upper position.	0/1	<input type="text" value=""/> <input type="text" value=""/> <input type="text" value="1"/> <input type="text" value="0"/> <input type="text" value=""/> <input type="text" value=""/> <input type="text" value="0"/>	33
11	Operation confirmation sound for operation panel	Operation confirmation sound for operation panel 0 : Operation confirmation sound is not generated 1 : Operation confirmation sound is generated.	0/1	<input type="text" value=""/> <input type="text" value=""/> <input type="text" value="1"/> <input type="text" value="1"/> <input type="text" value=""/> <input type="text" value=""/> <input type="text" value="1"/>	33
12	Optimal switch function selection	Switching of function of optional switch.		<input type="text" value=""/> <input type="text" value=""/> <input type="text" value="1"/> <input type="text" value="2"/> <input type="text" value=""/> <input type="text" value="o"/> <input type="text" value="P"/> <input type="text" value="T"/> <input type="text" value=""/>	34
* 13	Function of prohibiting start of the sewing machine by bobbin thread counter	Function of prohibiting start of the sewing machine by bobbin thread counting 0 : When counting is out (-1 or less) Function of prohibiting start of the sewing machine is not operative. 1 : When counting is out (-1 or less) Function of prohibiting start of the sewing machine after thread trimming is operative. 2 : When counting is out (-1 or less), the sewing machine stops once. Function of prohibiting start of the sewing machine after thread trimming is operative.	0 to 2	<input type="text" value=""/> <input type="text" value=""/> <input type="text" value="1"/> <input type="text" value="3"/> <input type="text" value=""/> <input type="text" value=""/> <input type="text" value="0"/>	
14	Sewing counter	Counting function of sewing (number of completion of process) 0 : Sewing counter function is not operative. 1 : Sewing counter function is operative. (Every time thread trimming is performed) 2 : With the sewing counting switch input function	0 to 2	<input type="text" value=""/> <input type="text" value=""/> <input type="text" value="1"/> <input type="text" value="4"/> <input type="text" value=""/> <input type="text" value=""/> <input type="text" value="1"/>	37
15	Thread wiping function after thread trimming	Thread wiping operation after thread trimming is specified. 0 : Thread wiping is not carried out after thread trimming 1 : Thread wiping is carried out after thread trimming	0/1	<input type="text" value=""/> <input type="text" value=""/> <input type="text" value="1"/> <input type="text" value="5"/> <input type="text" value=""/> <input type="text" value=""/> <input type="text" value="1"/>	
21	Function of automatic presser foot lifting at pedal's neutral position	Function of lifting presser foot when the pedal is in neutral position. 0 : Function of neutral automatic presser lifting is not operative. 1 : Selection of function of neutral presser lifting.	0/1	<input type="text" value=""/> <input type="text" value=""/> <input type="text" value="2"/> <input type="text" value="1"/> <input type="text" value=""/> <input type="text" value=""/> <input type="text" value="0"/>	37

* Do not change the set values with asterisk (*) mark as they are functions for maintenance. If the standard set value set at the time of delivery is changed, it is in danger of causing the machine to be broken or the performance to be deteriorated. If it is necessary to change the set value, please purchase the Engineer's Manual and follow the instructions.

No.	Item	Description	Setting range	Indication of function setting	Ref. page
22	Needle up/down correction switch changeover function	Function of the needle up/down correction switch is changed over. 0 : Needle up/down compensation 1 : One stitch compensation	0/1	<input type="text" value=""/> <input type="text" value=""/> <input type="text" value="2"/> <input type="text" value="2"/> <input type="text" value=""/> <input type="text" value=""/> <input type="text" value=""/> <input type="text" value="0"/>	37
25	Thread trimming operation after turning the handwheel by han	Thread trimming operation after moving the needle away from its upper or lower position by turning the handwheel by hand is specified. 0 : Thread trimming operation is carried out after turning the handwheel by hand 1 : Thread trimming operation is not carried out after turning the handwheel by hand	0/1	<input type="text" value=""/> <input type="text" value=""/> <input type="text" value="2"/> <input type="text" value="5"/> <input type="text" value=""/> <input type="text" value=""/> <input type="text" value=""/> <input type="text" value="1"/>	
29	Setting of one-touch type reverse feed solenoid pull-in time	This function sets the suction time of initial motion of back-tack solenoid. 50 ms to 500 ms	50 to 500 (ms)	<input type="text" value=""/> <input type="text" value=""/> <input type="text" value="2"/> <input type="text" value="9"/> <input type="text" value=""/> <input type="text" value="2"/> <input type="text" value="5"/> <input type="text" value="0"/>	37
30	Function of reverse feed stitching on the way	Function of reverse feed stitching on the way 0 : Normal one-touch type reverse feed stitching function 1 : Function of reverse feed stitching on the way is operative.	0/1	<input type="text" value=""/> <input type="text" value=""/> <input type="text" value="3"/> <input type="text" value="0"/> <input type="text" value=""/> <input type="text" value=""/> <input type="text" value=""/> <input type="text" value="0"/>	38
31	Number of stitches of reverse feed stitching on the way	Number of stitches of reverse feed stitching on the way.	0 to 19 (Stitches)	<input type="text" value=""/> <input type="text" value=""/> <input type="text" value="3"/> <input type="text" value="1"/> <input type="text" value=""/> <input type="text" value=""/> <input type="text" value=""/> <input type="text" value="4"/>	38
32	Effective condition of reverse feed stitching on the way when the sewing machine is stopping.	Effective condition of reverse feed stitching on the way 0 : Function is not operative when the sewing machine stops. 1 : Function is operative when the sewing machine stops.	0/1	<input type="text" value=""/> <input type="text" value=""/> <input type="text" value="3"/> <input type="text" value="2"/> <input type="text" value=""/> <input type="text" value=""/> <input type="text" value=""/> <input type="text" value="0"/>	38
33	Thread trimming function by reverse feed stitching on the way	Thread trimming function by reverse feed stitching on the way 0 : Automatic thread trimming function after completion of reverse feed stitching on the way is not operative. 1 : Automatic thread trimming after completion of reverse feed stitching on the way is performed.	0/1	<input type="text" value=""/> <input type="text" value=""/> <input type="text" value="3"/> <input type="text" value="3"/> <input type="text" value=""/> <input type="text" value=""/> <input type="text" value=""/> <input type="text" value="0"/>	38
* 35	Number of rotation at a low speed	Lowest speed by pedal (The MAX value differs by machine head.)	150 to MAX (sti/min)	<input type="text" value=""/> <input type="text" value=""/> <input type="text" value="3"/> <input type="text" value="5"/> <input type="text" value=""/> <input type="text" value="2"/> <input type="text" value="0"/> <input type="text" value="0"/>	
* 36	Number of rotation of thread trimming	Thread trimming speed (The MAX value differs by machine head.)	100 to MAX (sti/min)	<input type="text" value=""/> <input type="text" value=""/> <input type="text" value="3"/> <input type="text" value="6"/> <input type="text" value=""/> <input type="text" value="3"/> <input type="text" value="0"/> <input type="text" value="0"/>	
37	Number of rotation of soft-start	Sewing speed at the start of sewing (soft-start) (The MAX value differs by machine head.)	100 to MAX (sti/min)	<input type="text" value=""/> <input type="text" value=""/> <input type="text" value="3"/> <input type="text" value="7"/> <input type="text" value=""/> <input type="text" value="8"/> <input type="text" value="0"/> <input type="text" value="0"/>	33
38	One-shot speed	One-shot speed (The max. value depends on the number of rotation of the sewing machine head.)	150 to MAX (sti/min)	<input type="text" value=""/> <input type="text" value=""/> <input type="text" value="3"/> <input type="text" value="8"/> <input type="text" value=""/> <input type="text" value="2"/> <input type="text" value="5"/> <input type="text" value="0"/> <input type="text" value="0"/>	38
* 39	Pedal stroke at the start of rotation	Position where the sewing machine starts rotating from pedal neutral position (Pedal stroke)	10 to 50 (0.1 mm)	<input type="text" value=""/> <input type="text" value=""/> <input type="text" value="3"/> <input type="text" value="9"/> <input type="text" value=""/> <input type="text" value=""/> <input type="text" value="3"/> <input type="text" value="0"/>	
* 40	Low speed section of pedal	Position where the sewing machine starts accelerating from pedal neutral position (Pedal stroke)	10 to 100 (0.1 mm)	<input type="text" value=""/> <input type="text" value=""/> <input type="text" value="4"/> <input type="text" value="0"/> <input type="text" value=""/> <input type="text" value=""/> <input type="text" value="6"/> <input type="text" value="0"/>	
* 41	Starting position of lifting presser foot by pedal	Position where the cloth presser starts lifting from pedal neutral position (Pedal stroke)	- 60 to -10 (0.1mm)	<input type="text" value=""/> <input type="text" value=""/> <input type="text" value="4"/> <input type="text" value="1"/> <input type="text" value=""/> <input type="text" value=""/> <input type="text" value=""/> <input type="text" value="2"/> <input type="text" value="1"/>	
* 42	Starting position of lowering presser foot	Starting position of lowering presser foot Stroke from the neutral position	8 to 50 (0.1 mm)	<input type="text" value=""/> <input type="text" value=""/> <input type="text" value="4"/> <input type="text" value="2"/> <input type="text" value=""/> <input type="text" value=""/> <input type="text" value="1"/> <input type="text" value="0"/>	
* 43	Pedal stroke 2 for starting thread trimming	Position 2 where the thread trimming starts from pedal neutral position (When the function of lifting presser foot by pedal is provided.) (Pedal stroke) (Effective only when Item No. 50 is set at 1.)	- 60 to -10 (0.1 mm)	<input type="text" value=""/> <input type="text" value=""/> <input type="text" value="4"/> <input type="text" value="3"/> <input type="text" value=""/> <input type="text" value=""/> <input type="text" value=""/> <input type="text" value="5"/> <input type="text" value="1"/>	
* 44	Pedal stroke for reaching the maximum number of rotation	Position where the sewing machine reaches its highest sewing speed from pedal neutral position (Pedal stroke)	10 to 150 (0.1 mm)	<input type="text" value=""/> <input type="text" value=""/> <input type="text" value="4"/> <input type="text" value="4"/> <input type="text" value=""/> <input type="text" value="1"/> <input type="text" value="5"/> <input type="text" value="0"/>	
* 45	Compensation of neutral point of the pedal	Compensation value of the pedal sensor	-15 to 15	<input type="text" value=""/> <input type="text" value=""/> <input type="text" value="4"/> <input type="text" value="5"/> <input type="text" value=""/> <input type="text" value=""/> <input type="text" value=""/> <input type="text" value="0"/>	
47	Auto-lifter selecting function	Limitation time of waiting for lifting solenoid type auto-lifter device	10 to 600 (second)	<input type="text" value=""/> <input type="text" value=""/> <input type="text" value="4"/> <input type="text" value="7"/> <input type="text" value=""/> <input type="text" value=""/> <input type="text" value="6"/> <input type="text" value="0"/>	39
* 48	Pedal stroke 1 for starting thread trimming	Position where thread trimming starts from pedal neutral position (Standard pedal) (Pedal stroke) (Effective only when Item No. 50 is set at 0.)	- 60 to - 10 (0.1 mm)	<input type="text" value=""/> <input type="text" value=""/> <input type="text" value="4"/> <input type="text" value="8"/> <input type="text" value=""/> <input type="text" value=""/> <input type="text" value=""/> <input type="text" value="3"/> <input type="text" value="5"/>	
49	Lowering time of presser foot	Sets the time required until the lowering of the presser foot is completed after a depress on the pedal	0 to 500 (10 ms)	<input type="text" value=""/> <input type="text" value=""/> <input type="text" value="4"/> <input type="text" value="9"/> <input type="text" value=""/> <input type="text" value="1"/> <input type="text" value="4"/> <input type="text" value="0"/>	41

* Do not change the set values with asterisk (*) mark as they are functions for maintenance. If the standard set value set at the time of delivery is changed, it is in danger of causing the machine to be broken or the performance to be deteriorated. If it is necessary to change the set value, please purchase the Engineer's Manual and follow the instructions.

No.	Item	Description	Setting range	Indication of function setting	Ref. page
50	Pedal specification	Type of pedal sensor is selected. 0 : KFL 1 : PFL Refer to "III-10. Selection of the pedal specifications" p.43.	0/1	<input type="checkbox"/> <input type="checkbox"/> <input type="checkbox"/> <input type="checkbox"/> 5 0 <input type="checkbox"/> <input type="checkbox"/> <input type="checkbox"/> <input type="checkbox"/> 1	43
51	Compensation of solenoid-on timing of reverse feed stitching at the start of sewing	Compensation of starting the solenoid for reverse feed stitching when reverse feed stitching at the start of sewing is performed.	- 36 to 36 (10°)	<input type="checkbox"/> <input type="checkbox"/> <input type="checkbox"/> <input type="checkbox"/> 5 1 <input type="checkbox"/> <input type="checkbox"/> <input type="checkbox"/> <input type="checkbox"/> 1 2	39
52	Compensation of solenoid-off timing of reverse feed stitching at the start of sewing	Compensation of releasing the solenoid for reverse feed stitching when reverse feed stitching at the start of sewing is performed.	- 36 to 36 (10°)	<input type="checkbox"/> <input type="checkbox"/> <input type="checkbox"/> <input type="checkbox"/> 5 2 <input type="checkbox"/> <input type="checkbox"/> <input type="checkbox"/> <input type="checkbox"/> 1 8	39
53	Compensation of solenoid-off timing of reverse feed stitching at the end of sewing	Compensation of releasing the solenoid for reverse feed stitching when reverse feed stitching at the end of sewing is performed.	- 36 to 36 (10°)	<input type="checkbox"/> <input type="checkbox"/> <input type="checkbox"/> <input type="checkbox"/> 5 3 <input type="checkbox"/> <input type="checkbox"/> <input type="checkbox"/> <input type="checkbox"/> 1 6	39
55	Foot lift after thread trimming	Function of lifting presser foot at the time of (after) thread trimming 0 : Not provided with the function of automatic lifting of work-clamp after thread trimming 1 : Provided with the function of lifting presser foot automatically after thread trimming	0/1	<input type="checkbox"/> <input type="checkbox"/> <input type="checkbox"/> <input type="checkbox"/> 5 5 <input type="checkbox"/> <input type="checkbox"/> <input type="checkbox"/> <input type="checkbox"/> 1	40
56	Reverse revolution to lift the needle after thread trimming	Function of reverse revolution to lift the needle at the time of (after) thread trimming 0 : Not provided with the function of reverse revolution to lift the needle after thread trimming 1 : Provided with the function of reverse revolution to lift the needle after thread trimming	0/1	<input type="checkbox"/> <input type="checkbox"/> <input type="checkbox"/> <input type="checkbox"/> 5 6 <input type="checkbox"/> <input type="checkbox"/> <input type="checkbox"/> <input type="checkbox"/> 0	40
58	Function of holding predetermined upper/lower position of the needle bar	Function of holding predetermined upper/lower position of the needle bar 0 : Not provided with the function of holding predetermined upper/lower position of the needle bar 1 : Provided with the function of holding predetermined upper/lower position of the needle bar (holding force is weak.) 2 : Provided with the function of holding predetermined upper/lower position of the needle bar (holding force is medium.) 3 : Provided with the function of holding predetermined upper/lower position of the needle bar (holding force is strong.)	0 to 3	<input type="checkbox"/> <input type="checkbox"/> <input type="checkbox"/> <input type="checkbox"/> 5 8 <input type="checkbox"/> <input type="checkbox"/> <input type="checkbox"/> <input type="checkbox"/> 0	40
59	Function of Auto/Manual change-over of reverse feed stitching at the start of sewing	This function can specify the sewing speed of reverse feed stitching at the start of sewing. 0 : The speed will depend on the manual operation by pedal, etc. 1 : The speed will depend on the specified reverse feed stitching speed (No. 8).	0/1	<input type="checkbox"/> <input type="checkbox"/> <input type="checkbox"/> <input type="checkbox"/> 5 9 <input type="checkbox"/> <input type="checkbox"/> <input type="checkbox"/> <input type="checkbox"/> 1	40
60	Function of stop immediately after reverse feed stitching at the start of sewing	Function at the time of completion of reverse feed stitching at the start of sewing 0 : Not provided with the function of temporary stop of the sewing machine at the time of completion of reverse feed stitching at the start of sewing 1 : Provided with the function of temporary stop of the sewing machine at the time of completion of reverse feed stitching at the start of sewing.	0/1	<input type="checkbox"/> <input type="checkbox"/> <input type="checkbox"/> <input type="checkbox"/> 6 0 <input type="checkbox"/> <input type="checkbox"/> <input type="checkbox"/> <input type="checkbox"/> 0	40
64	Change-over speed of condensation stitch or EBT (end back tack)	Initial speed when starting condensation stitch or EBT	0 to 250 (sti/min)	<input type="checkbox"/> <input type="checkbox"/> <input type="checkbox"/> <input type="checkbox"/> 6 4 <input type="checkbox"/> <input type="checkbox"/> <input type="checkbox"/> <input type="checkbox"/> 1 8 0	
70	Function of soft-down of presser foot	Presser foot is slowly lowered. 0 : Presser foot is rapidly lowered. 1 : Presser foot is slowly lowered.	0/1	<input type="checkbox"/> <input type="checkbox"/> <input type="checkbox"/> <input type="checkbox"/> 7 0 <input type="checkbox"/> <input type="checkbox"/> <input type="checkbox"/> <input type="checkbox"/> 0	41
71	Double reverse feed stitching function	Effective/ineffective of double reverse feed stitching is changed over. 0 : Ineffective 1 : Effective	0/1	<input type="checkbox"/> <input type="checkbox"/> <input type="checkbox"/> <input type="checkbox"/> 7 1 <input type="checkbox"/> <input type="checkbox"/> <input type="checkbox"/> <input type="checkbox"/> 1	
72	Sewing machine startup selecting function	Current limit at the startup of sewing machine is specified. 0 : Normal (Current limit is applied during startup) 1 : Rapid (Current limit is not applied during startup)	0/1	<input type="checkbox"/> <input type="checkbox"/> <input type="checkbox"/> <input type="checkbox"/> 7 2 <input type="checkbox"/> <input type="checkbox"/> <input type="checkbox"/> <input type="checkbox"/> 0	
73	Retry function	This function is used when needle cannot pierce materials . 0 : Re-try function is not provided 1 - 10: Re-try function is provided (Needle-bar returning force before re-trying: 1 (small) - 10 (large))	0/1	<input type="checkbox"/> <input type="checkbox"/> <input type="checkbox"/> <input type="checkbox"/> 7 3 <input type="checkbox"/> <input type="checkbox"/> <input type="checkbox"/> <input type="checkbox"/> 1	41
76	One-shot function	One-shot operation up to the material end is specified. 0 : One-shot operation is not performed. 1 : One-shot operation is performed.	0/1	<input type="checkbox"/> <input type="checkbox"/> <input type="checkbox"/> <input type="checkbox"/> 7 6 <input type="checkbox"/> <input type="checkbox"/> <input type="checkbox"/> <input type="checkbox"/> 0	33
84	Initial motion suction time of presser foot lifting solenoid	Suction motion time of presser foot lifting solenoid	50 to 500 (ms)	<input type="checkbox"/> <input type="checkbox"/> <input type="checkbox"/> <input type="checkbox"/> 8 4 <input type="checkbox"/> <input type="checkbox"/> <input type="checkbox"/> <input type="checkbox"/> 2 5 0	41

* Do not change the set values with asterisk (*) mark as they are functions for maintenance. If the standard set value set at the time of delivery is changed, it is in danger of causing the machine to be broken or the performance to be deteriorated. If it is necessary to change the set value, please purchase the Engineer's Manual and follow the instructions.

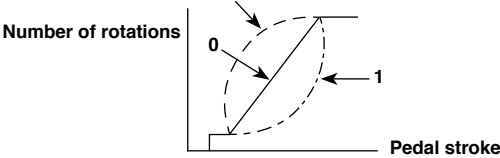
No.	Item	Description	Setting range	Indication of function setting	Ref. page
87	Function of pedal curve selection	Pedal curve is selected. (Improving pedal inching operation) 	0/1/2	<input type="text" value=""/> <input type="text" value=""/> <input type="text" value="8"/> <input type="text" value="7"/> <input type="text" value=""/> <input type="text" value=""/> <input type="text" value=""/> <input type="text" value="0"/>	41
90	Initial motion up stop function	Automatic UP stop function is set immediately after turning ON the power. 0 : off 1 : on	0/1	<input type="text" value=""/> <input type="text" value=""/> <input type="text" value="9"/> <input type="text" value="0"/> <input type="text" value=""/> <input type="text" value=""/> <input type="text" value=""/> <input type="text" value="1"/>	42
91	Function of prohibiting compensation operation after turning handwheel by hand	It is effective in combination with the machine head provided with tension release function. 0 : Tension release function is ineffective. 1 : Tension release function is effective.	0/1	<input type="text" value=""/> <input type="text" value=""/> <input type="text" value="9"/> <input type="text" value="1"/> <input type="text" value=""/> <input type="text" value=""/> <input type="text" value=""/> <input type="text" value="1"/>	
92	Function of reducing speed of reverse feed stitching at the start of sewing	Function to reduce speed at the time of completion of reverse feed stitching at the start of sewing. 0 : Speed is not reduced. 1 : Speed is reduced.	0/1	<input type="text" value=""/> <input type="text" value=""/> <input type="text" value="9"/> <input type="text" value="2"/> <input type="text" value=""/> <input type="text" value=""/> <input type="text" value=""/> <input type="text" value="0"/>	41
93	Function added to needle up/down compensating switch	Operation of needle up/down compensating switch is changed after turning ON the power or thread trimming. 0 : Normal (needle up/down compensating stitching only) 1 : One stitch compensating stitching is performed only when aforementioned changeover is made. (Upper stop → upper stop)	0/1	<input type="text" value=""/> <input type="text" value=""/> <input type="text" value="9"/> <input type="text" value="3"/> <input type="text" value=""/> <input type="text" value=""/> <input type="text" value=""/> <input type="text" value="0"/>	42
94	Continuous + One-shot nonstop function	The function that does not stop the sewing machine by combining continuous stitching with one-shot stitching using the program sewing function which is available in the IT operation panel. 0 : Normal (The sewing machine stops when a step is completed.) 1 : The sewing machine does not stop when a step is completed and proceeds to next step.	0/1	<input type="text" value=""/> <input type="text" value=""/> <input type="text" value="9"/> <input type="text" value="4"/> <input type="text" value=""/> <input type="text" value=""/> <input type="text" value=""/> <input type="text" value="0"/>	42
95	Head selection function	Machine head to be used is selected. (When the machine head is changed, each setting item is changed to the initial value of the machine head.)		<input type="text" value=""/> <input type="text" value=""/> <input type="text" value="9"/> <input type="text" value="5"/> <input type="text" value=""/> <input type="text" value="8"/> <input type="text" value="7"/> <input type="text" value="A"/> <input type="text" value="S"/>	
96	Max. number of rotation setting	Max. number of rotation of the sewing machine head can be set. (The MAX value differs by machine head.)	150 to MAX (sti/min)	<input type="text" value=""/> <input type="text" value=""/> <input type="text" value="9"/> <input type="text" value="6"/> <input type="text" value=""/> <input type="text" value="4"/> <input type="text" value="0"/> <input type="text" value="0"/> <input type="text" value="0"/>	42
100	Number of stitches sewn before thread clamp works at the beginning of sewing	Sets the number of stitches to be sewn at the beginning of sewing before the thread clamp solenoid (CN36-7) starts operating 0: Thread clamp solenoid does not operate. 1-9: The number of stitches to be sewn before the thread clamp solenoid operates	0-9 (stitches)	<input type="text" value=""/> <input type="text" value="1"/> <input type="text" value="0"/> <input type="text" value="0"/> <input type="text" value=""/> <input type="text" value=""/> <input type="text" value=""/> <input type="text" value="0"/>	
103	Needle cooler output OFF delay time	Delay time from the stop of sewing machine to the output OFF is specified using the needle cooler output function.	100 to 2000 ms	<input type="text" value=""/> <input type="text" value="1"/> <input type="text" value="0"/> <input type="text" value="3"/> <input type="text" value=""/> <input type="text" value="5"/> <input type="text" value="0"/> <input type="text" value="0"/>	
109	LED light dimmer utility setting	Used to adjust brightness of the LED light 0: Output OFF	0 to 100%	<input type="text" value=""/> <input type="text" value="1"/> <input type="text" value="0"/> <input type="text" value="9"/> <input type="text" value=""/> <input type="text" value="1"/> <input type="text" value="0"/> <input type="text" value="0"/>	42
120	Main shaft reference angle compensation	Main shaft reference angle is compensated.	-60 to 60	<input type="text" value=""/> <input type="text" value="1"/> <input type="text" value="2"/> <input type="text" value="0"/> <input type="text" value=""/> <input type="text" value=""/> <input type="text" value="1"/> <input type="text" value="3"/>	42
121	Up position starting angle compensation	Angle to detect UP position starting is compensated.	-15 to 15	<input type="text" value=""/> <input type="text" value="1"/> <input type="text" value="2"/> <input type="text" value="1"/> <input type="text" value=""/> <input type="text" value=""/> <input type="text" value=""/> <input type="text" value="5"/>	42
122	DOWN position starting angle compensation	Angle to detect DOWN position starting is compensated.	-15 to 15	<input type="text" value=""/> <input type="text" value="1"/> <input type="text" value="2"/> <input type="text" value="2"/> <input type="text" value=""/> <input type="text" value=""/> <input type="text" value=""/> <input type="text" value="0"/>	42
124	Setting of energy-saving function during standby	Setting to reduce the power consumption while the sewing machine is in standby state 0: Energy-saving mode is ineffective 1: Energy-saving mode is effective	0/1	<input type="text" value=""/> <input type="text" value="1"/> <input type="text" value="2"/> <input type="text" value="4"/> <input type="text" value=""/> <input type="text" value=""/> <input type="text" value=""/> <input type="text" value="0"/>	42

* Do not change the set values with asterisk (*) mark as they are functions for maintenance. If the standard set value set at the time of delivery is changed, it is in danger of causing the machine to be broken or the performance to be deteriorated. If it is necessary to change the set value, please purchase the Engineer's Manual and follow the instructions.

8. Detailed explanation of selection of functions

① Selection of the soft-start function (Function setting No. 1)

The needle thread may fail to interlace with the bobbin thread at the start of sewing when the stitching pitch (stitch length) is small or a thick needle is used. To solve such problem, this function (called "soft-start") is used to limit the sewing speed, thereby assuring successful formation of the starting stitches.

1 0

0 : The function is not selected.

1 to 9 : The number of stitches to be sewn under the soft-start mode.

The sewing speed limited by the soft-start function can be changed. (Function setting No. 37)

3 7 8 0 0

Data setting range

100 to MAX sti/min <10 sti/min> (The MAX value differs by machine head.)

② Material end sensor function (Function setting No. 2 to 4, 76)

This function is possible when the material end sensor is attached.

For details, refer to "III-16. Connection of the material end sensor" p. 49 and the Instruction Manual for the material end sensor.

③ Flicker reducing function (Function setting No. 5)

The function reduces flickering of the hand lamp at the start of sewing.

5 0

0 : Flicker reducing function is ineffective

1 : Flicker reducing function is effective

(Caution) When the flicker reducing function is set at the "Flicker reducing function is effective," the startup speed of the sewing machine decreases.

④ Bobbin thread counting function (Function setting No. 6)

When the control panel is used, the function subtracts from the predetermined value and indicates the used amount of bobbin thread.

For the details, refer to the instruction manual for the control panel.

6 1

0 : Bobbin thread counting function is not operative.

1 : Bobbin thread counting function is operative.

(Caution) If "0" is set, the LCD indication on the control panel will go out and the bobbin thread counting function will be invalid.

⑤ Thread trimming prohibiting function (Function setting No. 9)

This function turns OFF thread trimming solenoid output and wiper solenoid output when thread trimming is actuated.

By this function, separate sewing material can be spliced and sewn without trimming thread.

9 0

0 : off Thread trimming is operative. (thread can be trimmed).

1 : on Thread trimming is inoperative. (thread can not be trimmed).

⑥ Setting of the needle bar stop position when the sewing machine stops (Function setting No. 10)

The position of the needle bar when the pedal is in its neutral position is specified.

1 0 0

0 : Down The needle bar stops in the lowest position of its stroke.

1 : Up The needle bar stops in the highest position of its stroke.

(Caution) If the stop position of the needle bar is set to the highest position, the thread trimming action will be taken after the needle bar comes down once to the lowest position.

⑦ Panel operating sound (Function setting No. 11)

Whether the panel operation generates sound or not can be selected.

1 1 1

0 : off Operation confirmation sound is not generated

1 : on Operation confirmation sound is generated.

⑧ Selection of the optional input/output function (Function setting No. 12)

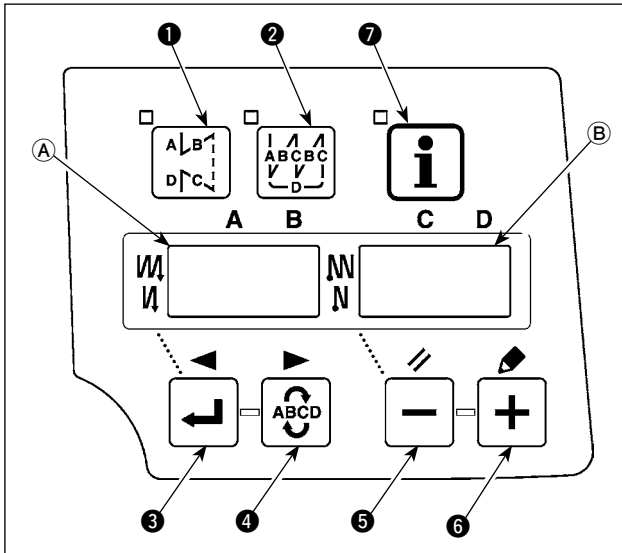

1 2 o P T

Select function setting No. 12 with the operating procedure of function setting procedures 1) through 3).

o P T E n d

i n

o u T

Select the items of "End", "in" and "ouT" with keys ⑤ and ⑥.

i 0 1 * * *

i 1 7

[When "in" is selected]

The input function setting connector indication number is shown on indicating section ①. Designate the indication number by means of key ③ or ④. Specify the function of the pin of the connector corresponding to the indication number by means of key ⑤ or ⑥.

Function code and abbreviation are displayed alternately on indicator ②. (For the relation between signal input No. and connector pin array, refer to the separate list.)

o 0 1 * * *

o 0 3

[When "ouT" is selected]

The output function setting connector indication number is shown on indicating section ①. Designate the indication number by means of key ③ or ④. Specify the function of the pin of the connector corresponding to the indication number by means of key ⑤ or ⑥.

Function code and abbreviation are displayed alternately on indicator ②. (Refer to the separate table for the relation between the signal output numbers and the connector pin configuration.)

* Example) To assign the thread trimming function to the input function setting connector indication number "i01" (CN36-4)

1 2 o P T

1. Select function setting No. 12 with the operating procedure of function setting procedures 1) through 3).

o P T i n

2. Select the item of "in" with keys ⑤ and ⑥.

i 0 1 n o P

3. Select the port of the indication number "i01" by means of key ④.

i 0 1 T S W

4. Select the thread trimming function, "TSW" with keys ⑤ and ⑥.

↕ Lighting alternately

L 4

5. Determine the thread trimming function, "TSW" with key ④.

i 0 1 L 4

6. Set ACTIVE of the signal with keys ⑤ and ⑥.

Set the display to "L" when the signal is "Low" and performing thread trimming, and set the display to "H" when the signal is "High" and performing thread trimming.

↑

H 4

i 0 2 S F S W

7. Determine the aforementioned function with key ④.

o P T i n

8. Finish the optional input with key ④.







o P T E n d

9. Select the item of "End" with keys ⑤ and ⑥ to return to the function setting mode.

Input function list

Function code	Abbreviation	Function item	Remarks
0	noP	No function	(Standard setting)
1	HS	Needle up / down compensating stitching	Every time the switch is pressed, normal feed stitching by half stitch is performed. (Same operation as that of up / down compensating stitching switch on the panel.)
2	bHS	Back compensating stitching	Reverse feed stitching is performed at low speed while the switch is held pressing.
3	EbT	Function of canceling once reverse feed stitching at the end of sewing	By depressing the back part of the pedal after pressing the switch, operation of reverse feed stitching is canceled once.
4	TSW	Thread trimming function	This function is actuated as the thread trimming switch.
5	FL	Presser foot lifting function	This function is actuated as the foot lifter switch.
6	oHS	One stitch compensating stitching	Every time the switch is pressed, one stitch stitching operation is executed.
7	SEbT	Function of cancel of reverse feed stitching at start/end	By operating the optional switch, ineffective/effective can be alternately changed over.
8	PnFL	Presser lifting function when pedal is neutral	Every time the switch is pressed, the function whether automatically lifting the presser foot when the pedal is neutral or not can be selected.
9	Ed	Material edge sensor input	This function works as the input signal of material edge sensor.
10	LinH	Function of prohibiting depressing front part of pedal	Rotation by pedal is prohibited.
11	TinH	Function of prohibiting thread trimming output	Output of thread trimming is prohibited.
12	LSSW	Low speed command input	This function works as low speed switch for standing sewing machine.
13	HSSW	High speed command input	This function works as high speed switch for standing sewing machine.
14	USW	Needle lifting function	UP stop motion is performed when switch is pressed during DOWN stop.
15	bT	Reverse feed stitching switch input	Reverse feed stitching is output as long as the switch is held pressed.
16	SoFT	Soft start switch input	The speed of stitch is limited to the predetermined soft-start speed as long as the switch is held pressed.
17	oSSW	One-shot speed command switch input	This function works as one-shot speed command as long as the switch is pressed.
18	bKoS	Backward one-shot speed command switch input	Reverse feed stitching is performed in accordance with the one-shot speed command as long as the switch is held pressed.
19	SFSW	Safety switch input	Rotation is prohibited.
20	MES	Thread trimming safety switch input	It operates as an input signal of the thread trimmer safety switch.
21	AUbT	Automatic reverse feed stitching cancellation/addition switch	Every time the switch is pressed, reverse feed stitching at sewing start or reverse feed stitching at sewing end is cancelled or added.
22	CUnT	Sewing counter input	Every time the switch is pressed, the sewing counter value is increased.
23	Tiin	Tsw command prohibition input	Thread trimming command is prohibited.
24	USTP	Lsw command prohibition/needle-up stop input	Sewing by means of the pedal switch is prohibited. The sewing machine stops with its needle up during sewing.

Input function setting connectors

Connector No.	Pin No.	Display No.	Initial value of function setting
CN36	4	i01	noP (No function setting)
CN54	3	i02	noP (No function setting)
CN50	12	i03	SoFT (Soft-start speed limit input)
CN36	5	i04	bT (Reverse feed stitching switch input)
CN50	11	i05	LinH (Input of prohibition of depress on front part of pedal)
CN39	7	i06	TSW (Thread trimming switch input)
	11	i07	LSSW (Low-speed revolution switch input)
	9	i08	HSSW (High-speed revolution switch input)
	5	i09	FL (Presser foot lifting switch input)
CN57	1	i10	CUnT (Sewing counter input)
Built-in panel		i11	noP (No function setting)
		i12	noP (No function setting)
		i13	noP (No function setting)
		i14	noP (No function setting)
		i15	noP (No function setting)
		i16	noP (No function setting)
		i17	noP (No function setting)

* The built-in panel settings i11 to i17 are only enabled when the external panel is connected to the sewing machine. Their numbers are not displayed when the external panel is not connected to the sewing machine.

Output function list

Function code	Abbreviation	Function item	Remarks
0	noP	No function	(Standard setting)
1	TrM	Thread trimming output	Output of thread trimming signal
2	WiP	Thread wiper output	Output of thread wiper signal
3	TL	Thread release output	Output of thread release signal
4	FL	Presser lifter output	Output of presser lifting signal
5	bT	Reverse feed stitching output	Output of reverse feed stitching signal
6	EbT	EBT cancel monitor output	State of one time cancel of reverse feed stitching at end function is output.
7	SEbT	Reverse feed stitching at start/end cancel monitor output	State of cancel of reverse feed stitching at start/end is output.
8	AUbT	Sewing start/end cancellation/addition monitor output	State of cancel or addition of automatic reverse feed stitching is output.
9	SSTA	Sewing machine stop state output	Sewing machine stop state is output.
10	Cool	Needle cooler output	Output for needle cooler
11	bUZ	Buzzer output	It is output when the bobbin counter set value has been exceeded, an error has occurred or the bobbin thread remaining amount is detected.
12	LSWo	Revolution command output	Revolution demanding command state is output.
13	TSWo	Tsw command monitor output	Thread trimming command status is output.

Output function setting connector

Connector No.	Pin No.	Display No.	Initial value of function setting
CN50	7	o01	bT (Reverse feed stitching output)
	8	o02	TrM (Thread trimming output)
	9	o03	LSWo (Revolution request input)

⑨ **Sewing counting function (Function setting No. 14)**

The function counts up every time thread trimming is completed and counts the number of completion of the sewing process.

1 4 **1**

- 0 : off Sewing counting function is inoperative.
- 1 : on Sewing counting function is operative. (Every time thread trimming is performed)
- 2 : on External sewing counter switch input.

The counter indication changes as shown below according to the combination of setting No. 6 and setting No. 14.

Setting No. 6	Setting No. 14	Counter
1	1	Bobbin counter
1	0	Bobbin counter
0	1	Sewing counter
0	0	Counter function is ineffective.

⑩ **Neutral automatic presser lifting function (with AK device only) (Functionsetting No. 21)**

This function can automatically lift the presser foot when the pedal is in the neutral position. Automatic lifting time of the pedal depends on the automatic lifting time after thread trimming and when the presser foot is automatically lowered, it is automatically lifted at the second neutral position after it has come off the neutral position once.

2 1 **0**

- 0 : off Function of neutral automatic presser lifting is not operative.
- 1 : on Selection of function of neutral automatic presser lifting

⑪ **Needle up/down switch function changeover function (Function setting No. 22)**

The needle up/down switch function can be changed over between the needle up/down compensating and one stitch compensating.

2 2 **0**

- 0 : Needle up / down compensating stitching
- 1 : One stitch compensating stitching

⑫ **Setting of the suction time of the back-tack solenoid (Function setting No. 29)**

This function can change the suction time of the back-tack solenoid.

It is effective to decrease the value when the heat is high.

(Caution) When the value is excessively decreased, failure of motion or defective pitch will follow.

Be careful when changing the value.

2 9 **2 5 0**

Setting range : 50 to 500 ms <10 / ms>

⑬ Function of reverse feed stitching on the way (Function setting Nos. 30 to 33)

Functions of the limit of number of stitches and thread trimming command can be added to the touch back switch on the sewing machine head.

Function setting No. 30 Function of reverse feed stitching on the way is selected.

3 **0** **0** 0 : off Normal back-tack function
 1 : on Function of reverse feed stitching on the way

Function setting No. 31 Number of stitches performing reverse feed stitching is set.

3 **1** **4** Setting range
 0 to 19 stitches

Function setting No. 32 Effective condition of reverse feed stitching on the way

3 **2** **0** 0 : off Inoperative when the sewing machine stops. (Reverse feed stitching on the way functions only when the sewing machine is running.)
 1 : on Operative when the sewing machine stops.
 (Reverse feed stitching on the way functions both when the sewing machine is running and stops.)

(Caution) Either condition is operative when the sewing machine is running.

Function setting No. 33 Thread trimming is performed when reverse feed stitching on the way is completed.

3 **3** **0** 0 : off Without thread trimming
 1 : on Thread trimming is executed.

Application	Function setting			Output function
	No.30	No.32	No.33	
①	0	0 or 1	0 or 1	It works as normal touch-back switch.
②	1	0	0	When operating touch-back switch at the time of depressing front part of the pedal, reverse feed stitching as many as the number of stitches specified by the function setting No. 31 can be performed.
③	1	1	0	When operating touch-back switch at the time of either stop of the sewing machine or depressing front part of the pedal, reverse feed stitching as many as the number of stitches specified by the function setting No. 31 can be performed.
④	1	0	1	When operating touch-back switch at the time of depressing front part of the pedal, automatic thread trimming is performed after reverse feed stitching as many as the number of stitches specified by the function setting No. 31 has been performed.
⑤	1	1	1	When operating touch-back switch at the time of either stop of the sewing machine or depressing front part of the pedal, automatic thread trimming is performed after reverse feed stitching as many as the number of stitches specified by the function setting No. 31 has been performed.

Actions under each setting state

- ① Used as the normal reverse feed stitching touch-back switch.
- ② Used for reinforcing seam (press sewing) of the pleats. (It works only when the sewing machine is running.)
- ③ Used for reinforcing seam (press sewing) of the pleats.
(It works either when the sewing machine stops or when the sewing machine is running.)
- ④ Used as starting switch for reverse feed stitching at the sewing end.
(Used as the substitute for thread trimming by depressing back part of the pedal. It works only when the sewing machine is running. It is especially effective when the sewing machine is used as the standing-work machine.)
- ⑤ Used as starting switch for reverse feed stitching at the sewing end.
(Used as the substitute for thread trimming by depressing back part of the pedal. It works either when the sewing machine stops or when the sewing machine is running. It is especially effective when the sewing machine is used as the standing-work machine.)

⑭ Number of rotation of one-shot stitching (Function setting No. 38)

This function can set, by the pedal operation of one time, the sewing speed of one-shot stitching when the sewing machine continues stitching until completing the number of stitches specified or detecting the material end.

3 **8** **2** **5** **0** **0** Setting range
 150 to MAX. sti/min. <50 / sti/min>

(Caution) The max. number of rotation of one-shot stitching is limited by the model of the sewing machine head.

⑮ Holding time of lifting presser foot (Function setting No. 47)

This function automatically lowers the presser foot when the time set with the setting No. 47 has passed after lifting the presser foot.

When the pneumatic type presser foot lifter is selected, the holding time control of lifting presser foot is limitless regardless of the set value.

Setting range
10 to 600 sec <10 / sec>

⑯ Compensation of timing of the solenoid for reverse feed stitching (Function setting No. 51 to 53)

When the normal and reverse feed stitches are not uniform under the automatic reverse feed stitching action, this function can change the ON / OFF timing of the solenoid for back tack and compensate the timing.

① Compensation of on-timing of solenoid for reverse feed stitching at the start of sewing (Function setting No. 51)

On-timing of solenoid for reverse feed stitching at the start of sewing can be compensated by the unit of angle.

Adjusting range
- 36 to 36 <1 / 10°>

Set value	Compensation angle	Number of stitches of compensation
- 36	- 360 °	- 1
- 18	- 180 °	- 0.5
0	0 °	0
18	180 °	0.5
36	360 °	1

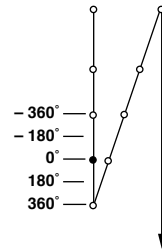

② Compensation of off-timing of solenoid for reverse feed stitching at the start of sewing (Function setting No. 52)

Off-timing of solenoid for reverse feed stitching at the start of sewing can be compensated by the unit of angle.

Adjusting range
- 36 to 36 <1 / 10°>

Set value	Compensation angle	Number of stitches of compensation
- 36	- 360 °	- 1
- 18	- 180 °	- 0.5
0	0 °	0
18	180 °	0.5
36	360 °	1

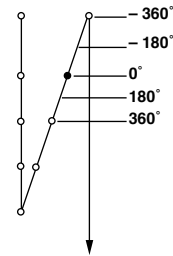

③ Compensation of off-timing of solenoid for reverse feed stitching at the end of sewing (Function setting No. 53)

Off-timing of solenoid for reverse feed stitching at the start of sewing can be compensated by the unit of angle.

Adjusting range
- 36 to 36 <1 / 10°>

Set value	Compensation angle	Number of stitches of compensation
- 36	- 360 °	- 1
- 18	- 180 °	- 0.5
0	0 °	0
18	180 °	0.5
36	360 °	1

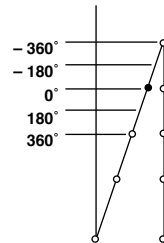

⑰ **Foot lift function after thread trimming (Function setting No. 55)**

This function can automatically lift the presser foot after thread trimming. This function is effective only when it is used in combination with the AK device.

5 5 1

- 0 : off Function of automatically lifting the presser foot is not provided.
(Presser foot does not automatically go up after thread trimming.)
- 1 : on Function of automatically lifting the presser foot is provided.
(Presser foot automatically goes up after thread trimming.)

⑱ **Reverse revolution to lift the needle after thread trimming (Function setting No. 56)**

This function is used to make the sewing machine rotate in the reverse direction after thread trimming to lift the needle bar almost to highest position. Use this function when the needle appears under the presser foot and it is likely to make scratches on the sewing products of heavy-weight material or the like.

5 6 0

- 0 : off Function of making the sewing machine rotate in the reverse direction to lift the needle after thread trimming is not provided.
- 1 : on Function of making the sewing machine rotate in the reverse direction to lift the needle after thread trimming is provided.

(Caution) The needle bar is raised, by rotating the machine in the reverse direction, almost to the highest dead point. This may result in slip-off of the needle thread. It is therefore necessary to adjust the length of thread remaining after thread trimming properly.

⑲ **Function of holding predetermined upper / lower position of the needle bar (Function setting No. 58)**

When the needle bar is in the upper position or in the lower position, this function holds the needle bar by applying a brake slightly.

5 8 0

- 0 : off Not provided with the function of holding predetermined upper/lower position of the needle bar
- 1 : on Provided with the function of holding predetermined upper/lower position of the needle bar (holding force is weak.)
- 2 : on Provided with the function of holding predetermined upper/lower position of the needle bar (holding force is medium.)
- 3 : on Provided with the function of holding predetermined upper/lower position of the needle bar (holding force is strong.)

⑳ **Change-over function of AUTO / Pedal for sewing speed of the reverse feed stitching at the start of sewing (Function setting No. 59)**

This function selects whether the reverse feed stitching at the start of sewing is performed without a break at the speed set by the function setting No. 8 or the stitching is performed at the speed by the pedal operation.

5 9 1

- 0 : Manual The speed is indicated by the pedal operation.
- 1 : Auto Automatic stitching at the specified speed

(Caution)

- 1. The max. sewing speed of the reverse feed stitching at the start of sewing is limited to the speed set by the function setting No. 8 regardless of the pedal.**
- 2. When "0" is selected, stitches of reverse feed stitching may not match those of normal feed stitching.**

㉑ **Function of stop immediately after the reverse feed stitching at the start of sewing (Function setting No. 60)**

This function temporarily stops the sewing machine even when keeping depressing the front part of the pedal at the time of completion of process of reverse feed stitching at the start of sewing.

It is used when sewing a short length by reverse feed stitching at the start of sewing.

6 0 0

- 0 : Not provided with the function of temporary stop of the sewing machine immediately after the reverse feed stitching at the start of sewing
- 1 : Provided with the function of temporary stop of the sewing machine immediately after the reverse feed stitching at the start of sewing

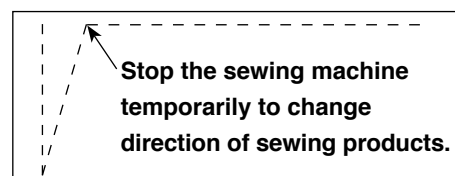

②② **Function of soft-down of presser foot (with AK device only) (Function setting No. 70 and 49)**

This function can softly lower the presser foot.

This function can be used when it is necessary to decrease contact noise, cloth defect, or slippage of cloth at the time of lowering the presser foot.

Note : Change the time of function setting No. 49 together at the time of selecting the function of soft-down since the sufficient effect cannot be obtained unless the time of function setting No. 49 is set longer when lowering the presser foot by depressing the pedal.

0 to 500 ms
10 ms/Step

0 : Function of soft-down of presser foot is not operative. (Presser foot is rapidly lowered.)
1 : Selection of function of soft-down of presser foot

②③ **Function of reducing speed of reverse feed stitching at the start of sewing (Function setting No. 92)**

Function to reduce speed at the time of completion of reverse feed stitching at the start of sewing : Normal use depending on the pedal condition (Speed is accelerated to the highest without a break.)

This function is used when temporary stop is used properly. (Cuff and cuff attaching)

0 : Speed is not reduced.
1 : Speed is reduced.

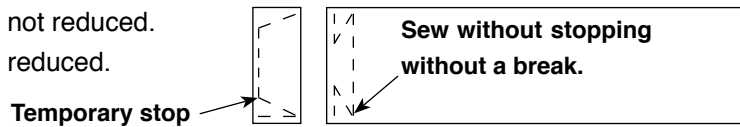

②④ **Retry function (Function setting No. 73)**

When the retry function is used, if the sewing material is thick and not pierced with needle, this function makes the needle pierce in the material with ease.

0 : Re-try function is not provided
1 - 10 : Re-try function is provided
(Needle-bar returning force before re-trying: 1 (small) - 10 (large))

②⑤ **Presser foot lifting solenoid suction time setting (Function setting No. 84)**

Suction time of presser foot lifting solenoid can be changed. When heating is great, it is effective to lessen the value.

(Caution) When the value is excessively small, malfunction will be caused. So, be careful when changing the value.

Setting range : 50 to 500ms <10/ms>

②⑥ **Function of pedal curve selection (Function setting No. 87)**

This function can perform the selection of the curve of number of rotation of the sewing machine against the depressing amount of the pedal.

Change to this function when you feel that inching operation is hard or that pedal response is slow.

0 : Number of rotation of the sewing machine in terms of the depressing amount of the pedal increases linearly.
1 : Reaction to intermediate speed in terms of the depressing amount of the pedal is delayed.
2 : Reaction to intermediate speed in terms of the depressing amount of the pedal is advanced.

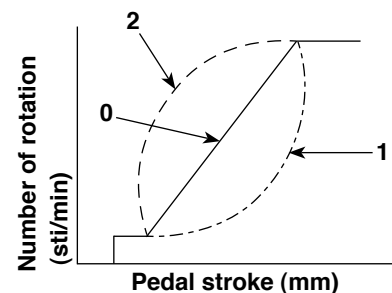

②7 Initial motion UP stop position move function (Function setting No. 90)

Effective/ineffective of automatic return to UP stop position immediately after turning ON the power can be set.

9 **0** **1** 0 : Ineffective
1 : Effective

②8 Function added to the needle up / down compensating switch (Function setting No. 93)

One stitch operation can be performed only when the needle up / down compensating switch is pressed at the time of upper stop immediately after turning ON the power switch or upper stop immediately after thread trimming.

9 **3** **0** 0 : Normal (Only needle up / down compensating stitching operation)
1 : One stitch compensating stitching operation (upper stop → upper stop)
is performed only when aforementioned changeover is made.

②9 Continuous stitching + one shot stitching nonstop function (Function setting No. 94)

This function is used to proceed a step to the next one without stopping the sewing machine at the end of the step when performing sewing with the continuous sewing and one-shot sewing combined using the programming function of the operation panel IT.

9 **4** **0** 0 : Normal (Stop when a step has completed.)
1 : The sewing machine proceeds to next step without stopping after a step has completed.

③0 Setting of max. number of rotation of the sewing machine head (Function setting No. 96)

This function can set the max. number of rotation of the sewing machine head you desire to use. Upper limit of the set value varies in accordance with the sewing machine head to be connected.

9 **6** **4** **0** **0** **0** 150 to Max. [sti/min] <50 / sti/min>

③1 LED light dimmer utility setting (Function setting No. 109)

Used to adjust brightness of the LED light

1 **0** **9** **1** **0** **0** Setting range
0 to 100

③2 Main shaft reference angle compensation (Function setting No. 120)

Main shaft reference angle is compensated

1 **2** **0** **-** **2** **3** Setting range
- 60 to 60° <1 / °>

③3 UP position starting angle compensation (Function setting No. 121)

Angle to detect UP position starting is compensated.

1 **2** **1** **5** Setting range
- 15 to 15° <1 / °>

③4 DOWN position starting angle compensation (Function setting No. 122)

Angle to detect DOWN position starting is compensated.

1 **2** **2** **0** Setting range
- 15 to 15° <1 / °>

③5 Setting of energy saving function during standby (Function setting No. 124)

It is possible to reduce power consumption while the sewing machine is in standby state. It should be noted that the startup of the sewing machine may delay for a moment if this function is set.

1 **2** **4** **0** 0 : Energy-saving mode is ineffective.
1 : Energy-saving mode is effective.

9. Automatic compensation of neutral point of the pedal sensor

Whenever the pedal sensor, spring, etc. are replaced, be sure to perform following operation :

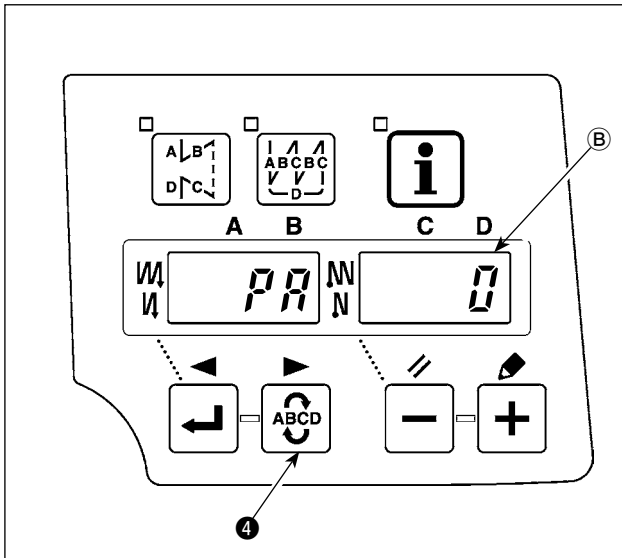

- 1) Pressing switch  ④, turn ON the power switch.
- 2) Compensated value is displayed on indicator ⑤.
(Caution) 1. At this time, the pedal sensor does not work properly if the pedal is depressed. Do not place the foot or any object on the pedal. Warning sound "blips" and the correct compensation value is not displayed.
2. If any display ("-0-" or "-8-") other than a numeric value appears on indicator ⑤, refer to the Engineer's Manual.
- 3) Turn OFF the power switch, and turn ON the power switch again to return to the normal mode.

(Caution) Be sure to re-turn ON the power switch when one or more seconds have passed after turning it OFF. (If the ON-OFF operation is carried out faster than the above, the setting may not change normally.)

10. Selection of the pedal specifications

When the pedal sensor has been replaced, change the set value of function setting No. 50 according to the newly connected pedal specifications.

- 0 : KFL
- 1 : PFL

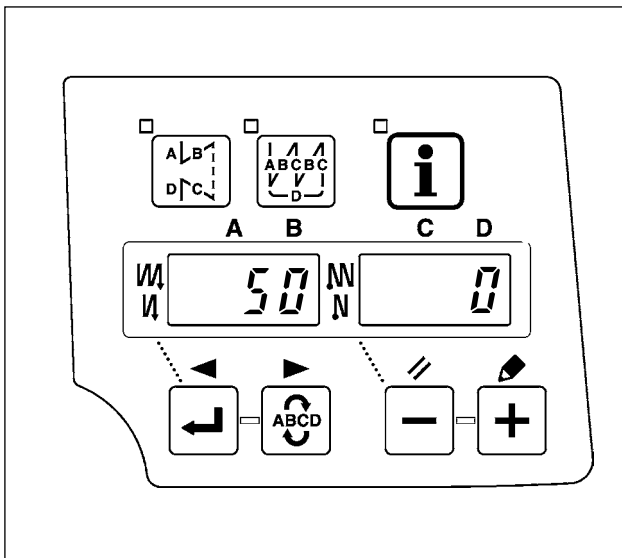

(Caution) Pedal sensor with two springs located at the back part of the pedal type is PFL, and that with one spring type is KFL. Set the pedal sensor to PFL when lifting the presser foot by depressing the back part of the pedal.

11. Setting of the auto lifter function



WARNING :

When the solenoid is used with the air drive setting, the solenoid may be burned out. So, do not mistake the setting.

When the auto-lifter device (AK) is attached, this function makes the function of auto-lifter work.

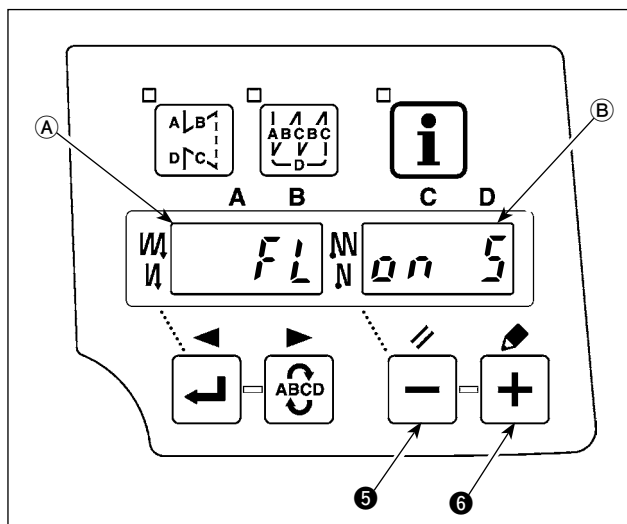

- 1) Turn ON the power switch with switch ⑤ held pressed.
- 2) "FL ON" is displayed on indicators ① and ② with a blip to make the auto lifter function effective.
- 3) Turn OFF the power switch, and turn ON the power switch again to return to the normal mode.
- 4) Repeat the operation 1) to 3), and LED display is turned to (FL OFF). Then, the function of auto-lifter does not work.

FL ON : Auto-lifter device becomes effective. Selection of the auto-lifter device of solenoid drive (+33V) or of air drive (+24V) can be performed with switch ⑥.

(Changeover is performed to drive power +33V or +24V of CN37.)

Solenoid drive display (+33V)

Air drive display (+24V)

FL OFF : Auto-lifter function does not work. (Similarly, the presser foot is not automatically lifted when programmed stitching is completed.)

- (Caution)
1. To perform re-returning ON of the power, be sure to perform after the time of one second or more has passed. (If ON / OFF operation of the power is performed quickly, setting may be not changed over well.)
 2. Auto-lifter is not actuated unless this function is properly selected.
 3. When "FL ON" is selected without installing the auto-lifter device, starting is momentarily delayed at the start of sewing. In addition, be sure to select "FL OFF" when the auto-lifter is not installed since the touch-back switch may not work.

12. Selecting procedure of the key-lock function

Setting of the number of stitches for a pattern can be prohibited by enabling the key lock function.

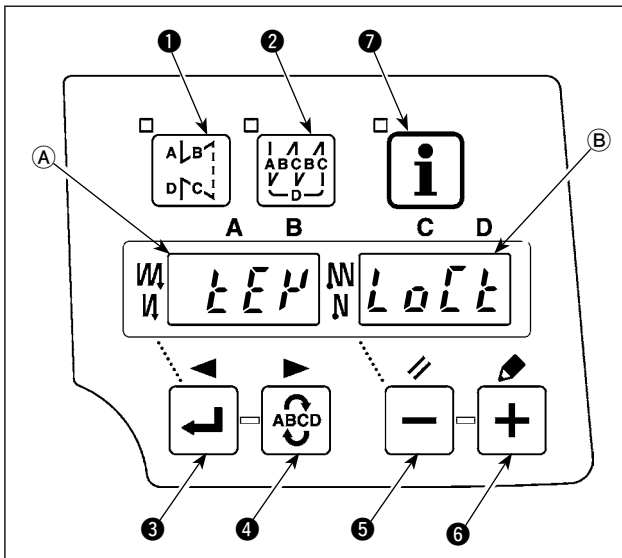

- 1) Turn ON the power switch with switch ⑤ and switch ⑥ held pressed.
- 2) "KEY LOCK" is displayed on indicators ① and ② with a blip to make the key-lock function effective.
- 3) The panel returns to the normal operation after displaying "KEY LOCK" on the indicators.
- 4) While the key lock function is effective, "KEY LOCK" is displayed on the indicators when turning the power ON.

- 5) When you carry out steps 1) to 3) in repetition, "KEY LOCK" is not displayed when turning the power ON and the key lock function is rendered ineffective.

- KEY LOCK display when turning the power ON

Display appears: The key lock function is effective.

Display does not appear: The key lock function is ineffective.

In the case the key lock function is effective, the operation of the panel will be as shown in the table below. (Pattern indication number)

· In the case the operation is disabled	Setting of the number of stitches for a pattern (④)
· Functions that are operated in the same procedure as in the case of normal operation state	Change of the sewing pattern (① and ②) Changeover of the reverse feed stitching (③ and ⑤) Production support function (⑦)

13. Removing the rear cover



WARNING :

To prevent personal injuries caused by electric shock hazards or abrupt start of the sewing machine, remove the cover after turning OFF the power switch and a lapse of 5 minutes or more. To prevent personal injuries, when a fuse has blown out, be sure to replace it with a new one with the same capacity after turning OFF the power switch and removing the cause of the blown-out of the fuse.

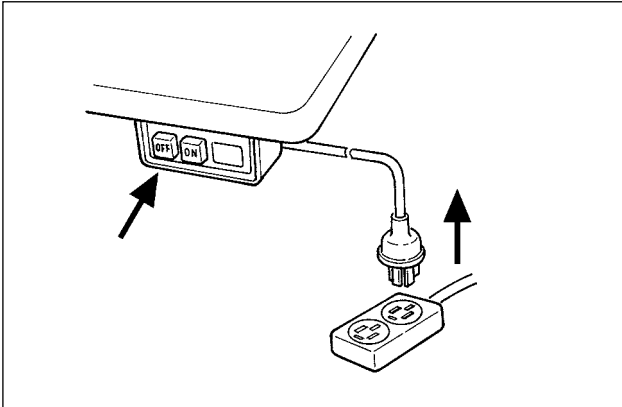

- 1) Press the OFF button of the power switch to turn OFF the power after confirming that the sewing machine has stopped.
- 2) Draw out the power cord coming from the power plug socket after confirming that the power switch is turned OFF. Perform the work of step 3) after confirming that the power has been cut and it has passed for 5 minutes or more.

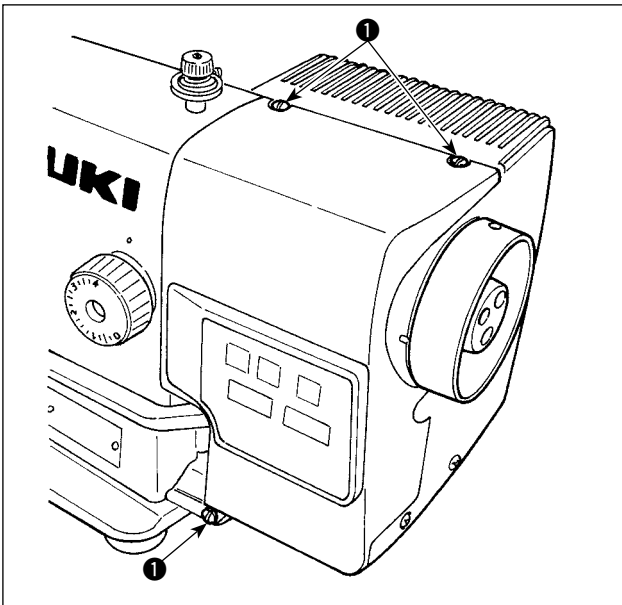

- 3) Remove three screws ❶ which fasten the front cover and rear cover together.

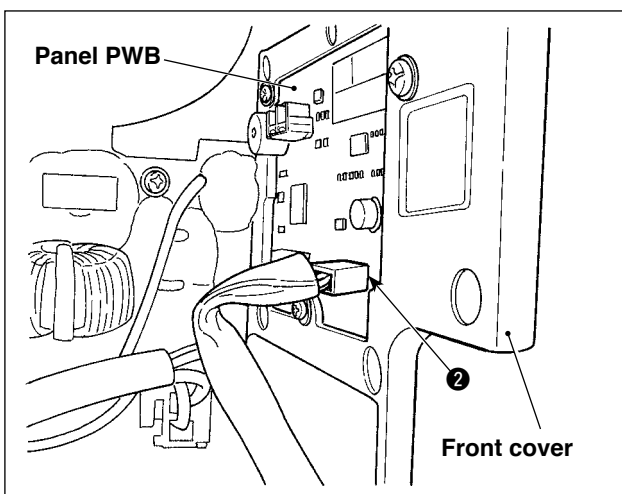

- 4) Remove the front cover partly. Remove the panel cable, which is connected to the panel PWB inside the cover, from connector ❷ (CN200: 4P).

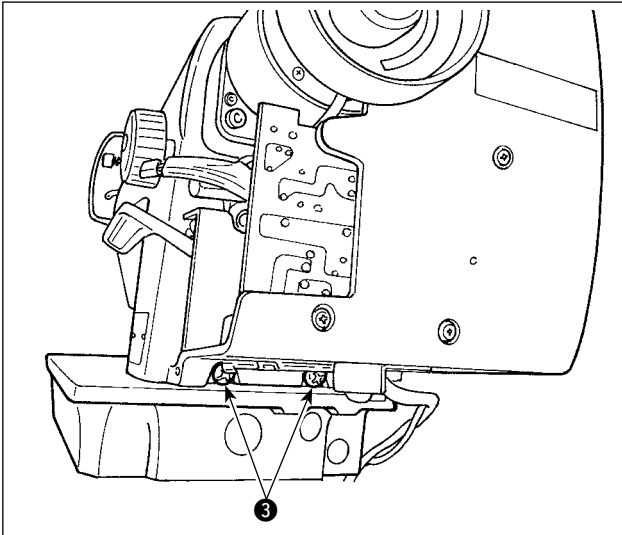

- 5) Remove two screws **3** from the lower part of the rear cover.

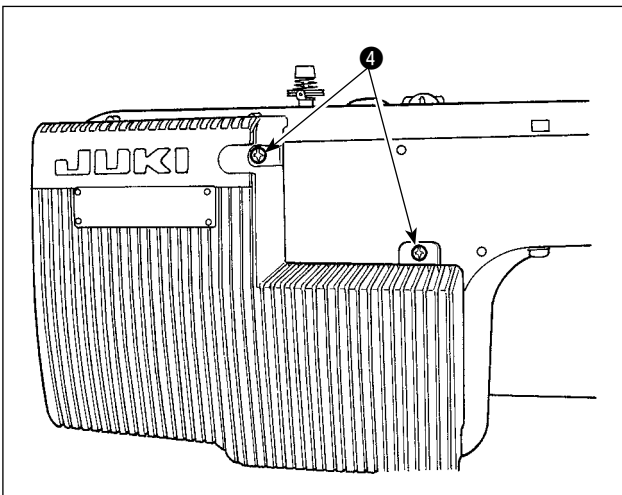

- 6) Remove screw **4** from the rear face of the rear cover.

- 7) Move the rear cover backward and carefully tilt it.

14. Connection of the pedal of standing-work machine

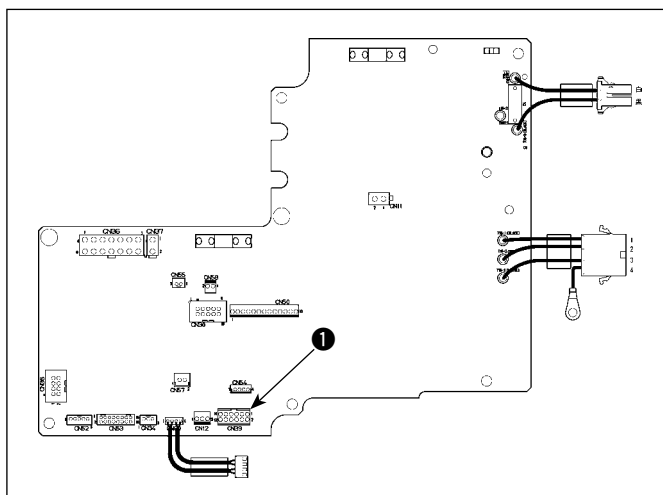

1) Open the cover referring to "**III-13. Removing the rear cover**" p.46.

2) Insert the PK-70 and -71 connectors into connectors **1** (CN39: 12P).

(Caution) Be sure to turn OFF the power before connecting the connector.

15. External input / output connector

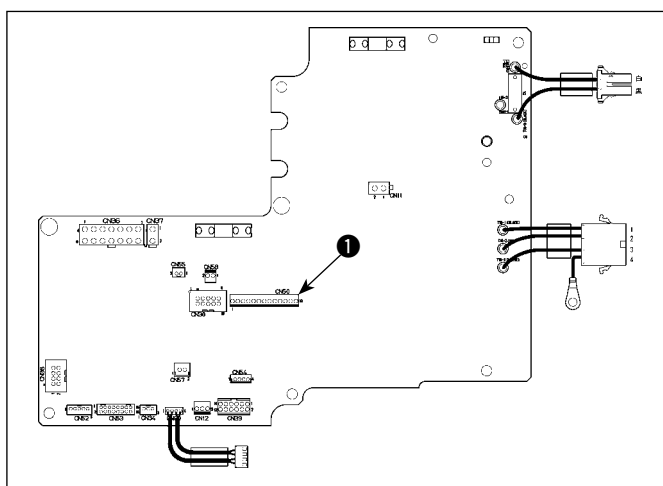

External input/output connector (CN50) **1** which can take out the following signals that are convenient when installing counter or the like outside is prepared.

(Caution) When using the connector, note that the engineer who has the electrical knowledge has to work.

Table of assignment of connector and signal

CN50	Signal name	Input / output	Description	Electric spec.
1	+5V	-	Power source	
2	MA	Output	Rotation signal 360 pulses/rotation	DC5V
3	MB	Output	-	DC5V
4	UDET(N)	Output	"L" is output when needle bar is at LOW position.	DC5V
5	DDET(N)	Output	"L" is output when needle bar is at UP position.	DC5V
6	HS(N)	Output	Rotation signal 45 pulses/rotation	DC5V
7	BTD(N)	Output	"L" is output when the back-tack solenoid works.	DC5V
8	TRMD(N)	Output	"L" is output when the thread trimmer solenoid works.	DC5V
9	LSWO(P)	Output	Rotation request (pedal or the like) monitor signal	DC5V
10	S.STATE(N)	Output	"L" is output when the sewing machine is in the stop state.	DC5V
11	LSWINH(N)	Input	Rotation by pedal is prohibited while "L" signal is being inputted.	DC5V, -5mA
12	SOFT	Input	Rotation speed is limited to the soft-speed while "L" signal is being inputted.	DC5V, -5mA
13	SGND	-	0V	

JUKI genuine part No.

Connector : Part No. HK016510130

Pin contact : Part No. HK016540000

16. Connection of the material end sensor

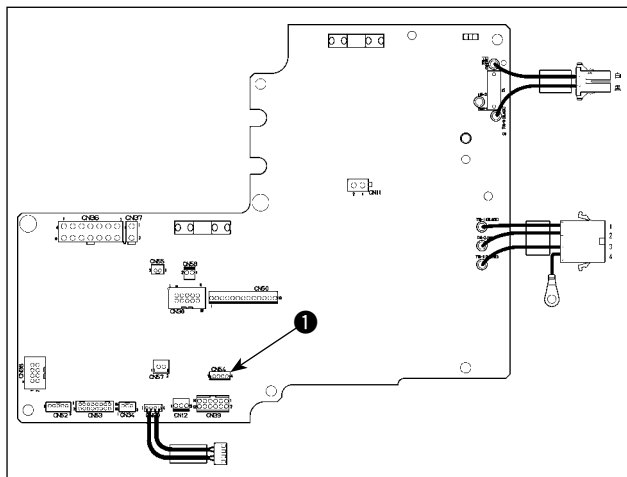

- 1) Open the cover referring to "[III-13. Removing the rear cover](#)" p.46.
- 2) Connect the connector of material end sensor to connector ❶ (CN54 : 4P).
- 3) Assign CN54 to the material end sensor input referring to "[III-8-⑧. Selection of the optional input/output function \(Function setting No. 12\)](#)" p.34.
- 4) To use the material end sensor, set up the sensor functions on the control box through the function setting procedure. Selectable functions and the corresponding selection numbers are as follows:

Pin No.	Signal name	Remarks
1	+12V	Power supply is selected according to the sensor used.
2	+5V	
3	OPT_S	Sensor input is assigned to the material end sensor.
4	GND	

- Material end sensor function (function setting No. 2)
The material end sensor is enabled.

2 1

0: Material end sensor is not used.
1: Material end sensor is enabled.

- Thread trimming function by means of the material end sensor (function setting No. 3)
The automatic thread trimmer is activated after the detection of the material end.

3 1

0: Automatic thread trimming is not carried out.
1: Automatic thread trimming is carried out.

- The number of stitches after the activation of the material end sensor (function setting No. 4)
The number of stitches to be sewn until the sewing machine stops after the material end sensor has detected the material end can be specified.

4 5

Data setting range: 0 - 19 <1/stitch>

- One-shot function (function setting No. 76)
The one-shot operation until the material end is detected can be set.

7 6 0

0: One-shot operation is not carried out.
1: One-shot operation is carried out.



- (Caution)**
1. Be sure to turn OFF the power before connecting the connector.
 2. For the use of the material end sensor, refer to the Instruction Manual attached to the material end sensor.

JUKI genuine part number Connector HK042310040
Pin contact HK042340000

17. Initialization of the setting data

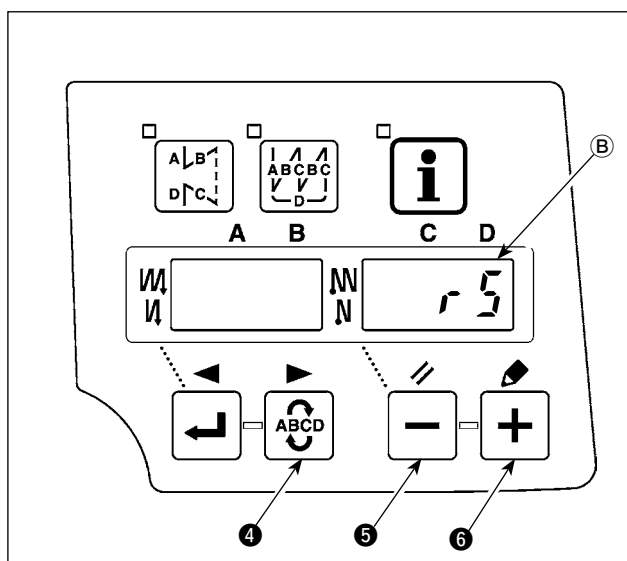
All contents of function setting of DDL-8700A-7 can be returned to the standard set values.



- 1) Turn ON the POWER switch with all of switch  ④, switch  ⑤ and  switch ⑥ held pressed.
 - 2) "rS" is displayed on indicator ② with a blip to start initialization.
 - 3) The buzzer sounds after approximately one second (single sound three times, "peep", "peep", and "peep"), and the setting data returns to the standard setting value.
- (Caution) Do not turn OFF the power on the way of initializing operation. Program of the main unit may be broken.**
- 4) Turn OFF the power switch and turn ON the power switch after closing the front cover. The machine returns to the normal motion.

- (Caution)**
1. When you carry out the aforementioned operation, the neutral position correction value for the pedal sensor is also initialized. It is therefore necessary to carry out automatic correction of the pedal sensor neutral position before using the sewing machine. (Refer "[III-9. Automatic compensation of neutral point of the pedal sensor](#)" p.43.)
 2. When you carry out the aforementioned operation, the machine-head adjustment values are also initialized. It is therefore necessary to carry out adjustment of the machine head before using the sewing machine. (Refer "[IV-2. Adjusting the machine head](#)" p.52.)
 3. Even when this operation is performed, the sewing data set by the operation panel cannot be initialized.

IV. MAINTENANCE

1. Replacing the fuse

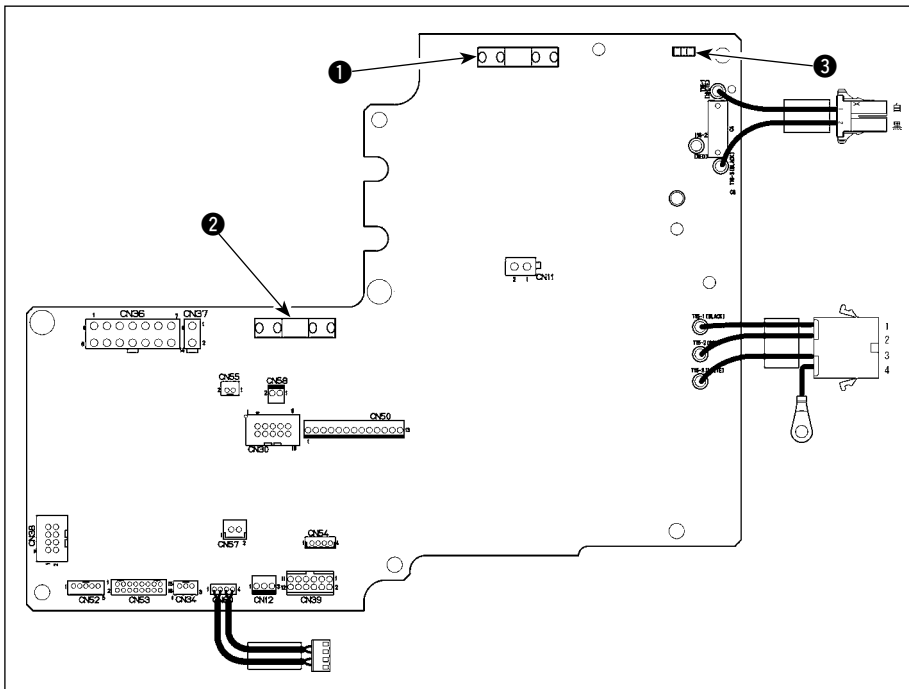

- 1) Check that the sewing machine is at rest. Press the OFF button of the power switch to turn the power OFF.
- 2) Check that the power switch is in the OFF state. Remove the power cord from the plug receptacle.
- 3) Open the cover referring to "[III-13. Removing the rear cover](#)" p.46.

- 4) Remove fuses ① and ② by holding their glass section.

(Caution) This work poses a risk of electric shock. Be sure to remove the fuses after LED ③ has completely gone out.

- 5) Use the fuse which has the specified fuse capacity.

① : 3.15 A/250 V Time-lag fuse
Part number: KF000000080

② : 6.3 A/250 V Time-lag fuse
Part number: KF000000030

2. Adjusting the machine head

(Caution) When the slip between the white marker dot on the handwheel and the concave of the cover is excessive after thread trimming, adjust the angle of the machine head by the operation below.

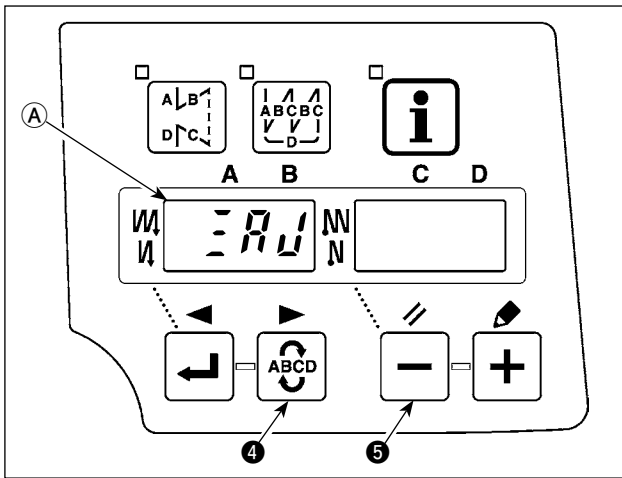

- 1) Simultaneously pressing switch ④ and switch ⑤, turn ON the power switch.
- 2) is displayed (A) in the indicator and the mode is changed over to the adjustment mode.

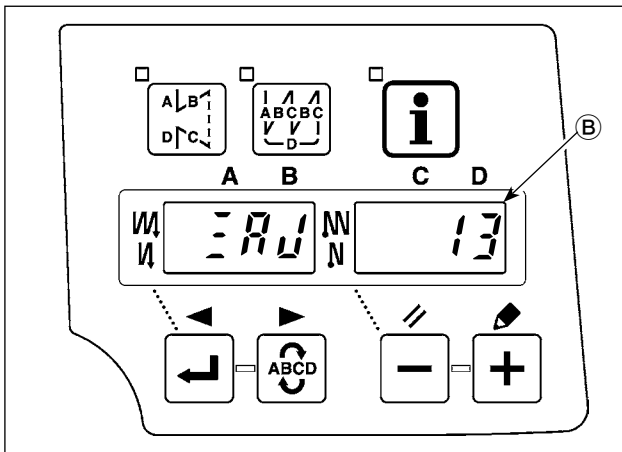

- 3) Turn the pulley of the machine head by hand until the main-shaft reference signal is detected. At this time, the degree of an angle from the main-shaft reference signal is displayed on the indicator (B). (The value is the reference value.)

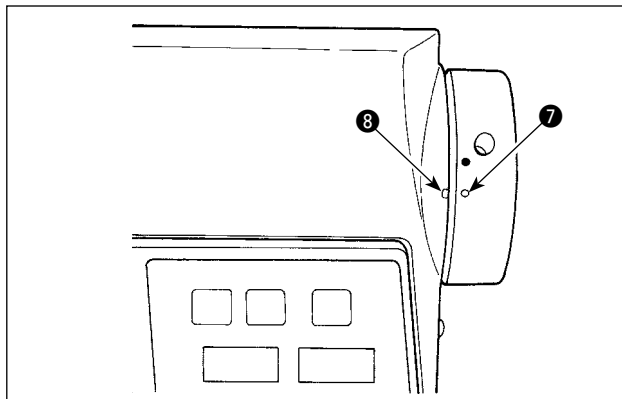

- 4) In this state, align the white dot ⑦ of the handwheel with the concave ⑧ of the pulley cover as shown in the figure.

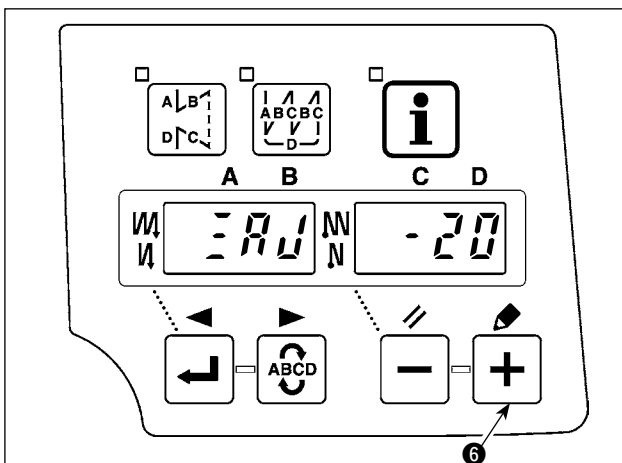

- 5) Press switch ⑥ to finish the adjustment work. (The value is the reference value.)

3. Connector layout drawing

WARNING :



- To protect against personal injury resulting from abrupt start of the sewing machine, be sure to turn the power OFF, unplug the machine and wait for five minutes or more before connecting the connectors.
- To prevent damage of device caused by maloperation and wrong specifications, be sure to connect all the corresponding connectors to the specified places. (If any of the connectors is inserted into a wrong connector, not only the device corresponding to the connector can break but also it can start abruptly, inviting the risk of personal injury.)
- To prevent personal injury caused by maloperation, be sure to lock the connector with lock.
- As for the details of handling respective devices, read carefully the Instruction Manuals supplied with the devices before handling the devices.

Following connectors are prepared on the front face of MAIN board.
 Connect the connectors coming from the machine head to the corresponding places so as to fit the devices mounted on the machine head.

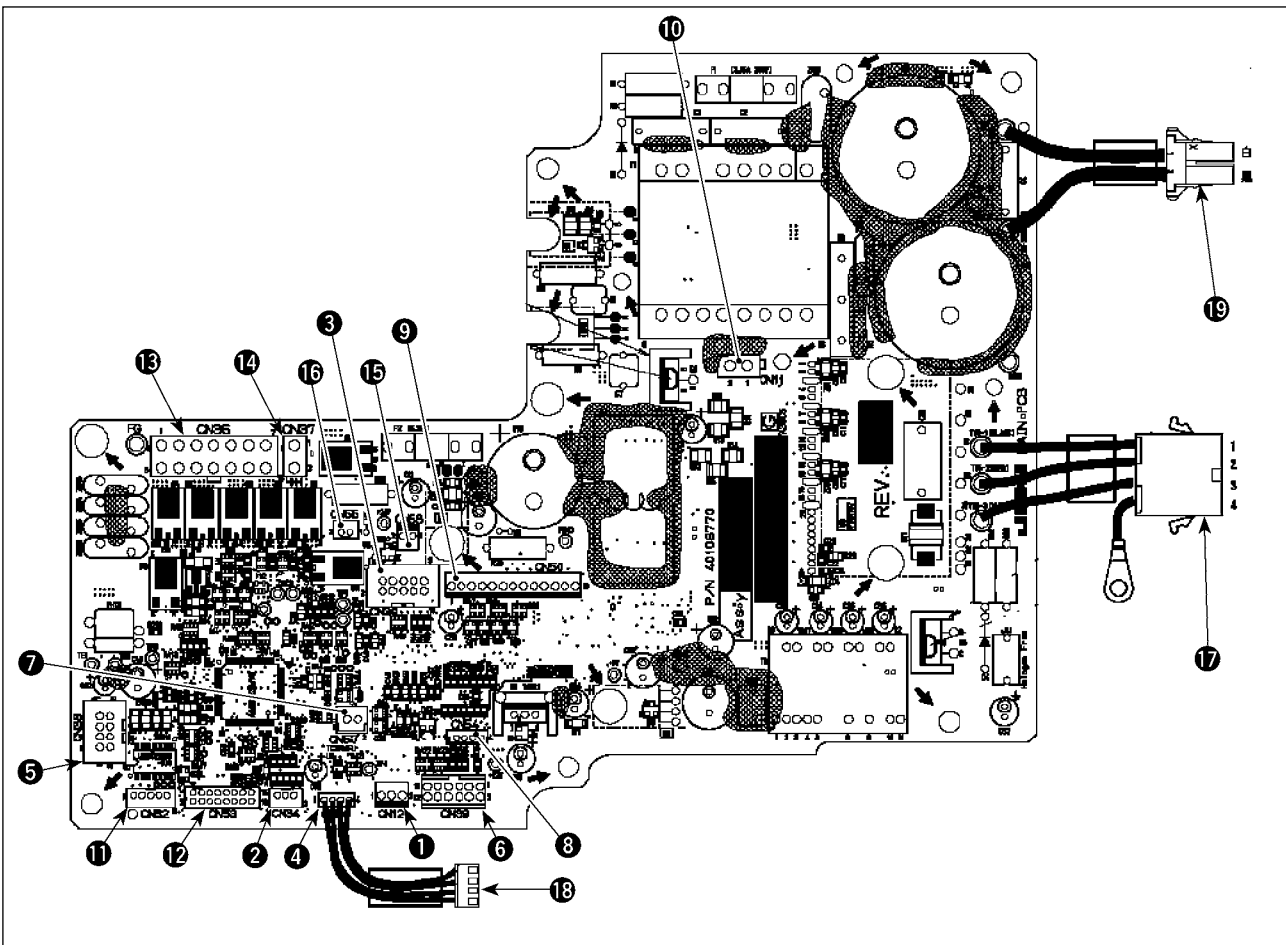

- | | |
|-----------------------------------|---------------------------------------|
| ① CN12 : Connector for relay cord | ⑪ CN52 : CPU INSYSTEM |
| ② CN34 : Pedal sensor | ⑫ CN53 : JTAG |
| ③ CN30 : Motor encoder | ⑬ CN36 : Machine head solenoid |
| ④ CN60 : Machine head panel | ⑭ CN37 : Presser foot lifter solenoid |
| ⑤ CN38 : CP/IP panel | ⑮ CN58 : Fan |
| ⑥ CN39 : Standing-work machine | ⑯ CN55 : LED light |
| ⑦ CN57 : Production control | ⑰ Motor cable |
| ⑧ CN54 : OPTION INPUT | ⑱ Panel cable |
| ⑨ CN50 : OPTION I/O | |
| ⑩ CN11 : Regenerative resistance | ⑲ Power cord |

4. Error codes





In case of the following, check again before you judge the case as trouble.

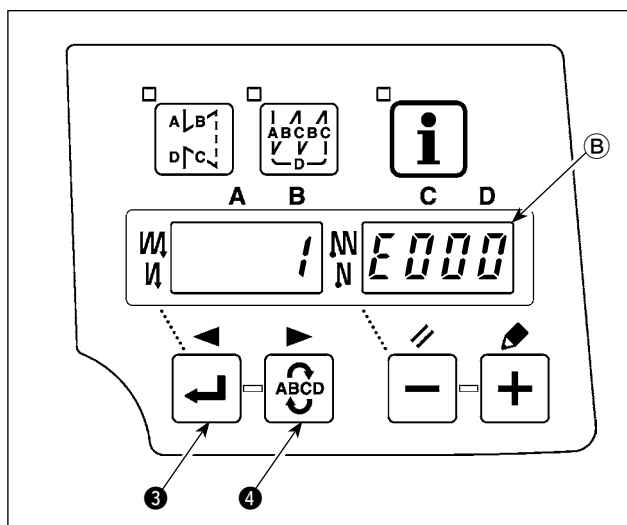

Phenomenon	Cause	Corrective measure
When tilting the sewing machine, the buzzer beeps and the sewing machine cannot be operated. Solenoids for thread trimming	When tilting the sewing machine without turning OFF the power switch, Action given on the left side is taken for safety sake.	Tilt the sewing machine after turning OFF the power.
Solenoids for thread trimming, reverse feed, wiper, etc. fail to work. Hand lamp does not light up.	When the fuse for solenoid power protection has blown out	Check the fuse for solenoid power protection.
Even when depressing the pedal immediately after turning ON the power, the sewing machine does not run. When depressing the pedal after depressing the back part of pedal once, the sewing machine runs.	Neutral position of the pedal has varied. (Neutral position may be shifted when changing spring pressure of the pedal or the like.)	Execute the automatic neutral correction function of the pedal sensor.
The sewing machine does not stop even when the pedal is returned to its neutral position.		
Presser foot does not go up even when auto-lifter device is attached.	Auto-lifter function is OFF.	Select "FL ON" by auto-lifter function selection.
	Pedal system is set to KFL system.	Change the jumper to PFL setting to lift the presser foot by depressing the back part of the pedal.
	Cord of auto-lifter device is not connected to connector (CN37).	Connect the cord properly.
Touch-back switch fails to work.	Presser foot is going up by auto-lifter device.	Operate the switch after the presser foot lowered.
	Auto-lifter device is not attached. However, auto-lifter function is ON.	Select "FL OFF" when auto-lifter device is not attached.
Sewing machine fails to run.	Motor output cord (4P) is disconnected.	Connect the cord properly.
	Connector (CN30) of motor signal cord is disconnected.	Connect the cord properly.

In addition, there are the following error codes in this device. These error codes interlock (or limit function) and inform the problem so that the problem is not enlarged when any problem is discovered. When you request our service, please confirm the error codes.



[Checking procedure of the error code]

- 1) Turn ON the power switch with  switch ③ held pressed.
- 2) The latest error number is displayed on indicator  with a blip.
- 3) Contents of previous errors can be checked by pressing  switch ③ or  switch ④.
(When the confirmation of the contents of previous error advanced to the last, the warning sound peeps in single tone two times.)

(Caution) When  switch ③ is pressed, the previous error code of the currently displayed one is displayed. When  switch ④ is pressed, the next error code of the currently displayed one is displayed.

Error code list

No.	Description of error detected	Cause of occurrence expected	Items to be checked
E000	Execution of data initialization (This is not the error.)	<ul style="list-style-type: none"> • When the machine head is changed. • When the initialization operation is executed. 	
E003	Disconnection of synchronizer connector	<ul style="list-style-type: none"> • When position detection signal is not input from the sewing machine head synchronizer. • When the synchronizer has broken. 	<ul style="list-style-type: none"> • Check the synchronizer connector (CN33) for loose connection and disconnection.
E004	Synchronizer lower position sensor failure		
E005	Synchronizer upper position sensor failure		
E007	Overload of motor	<ul style="list-style-type: none"> • Belt is loose. • Machine head is not proper. • Motor pulley is not proper. 	<ul style="list-style-type: none"> • Check whether the thread has been entangled in the motor pulley. • Check the motor output connector (4P) for loose connection and disconnection. • Check whether there is any holdup when turning the motor by hand.
E070	Slip of belt	<ul style="list-style-type: none"> • When the machine head is locked. • Belt is loose. 	
E071	Disconnection of motor output connector	<ul style="list-style-type: none"> • Disconnection of motor connector. 	
E072	Overload of motor at the time of thread trimming motion	<ul style="list-style-type: none"> • Same as E007. 	<ul style="list-style-type: none"> • Same as E007.
E079	Automatic operation overload error	<ul style="list-style-type: none"> • Not used 	<ul style="list-style-type: none"> • Not used
E220	Grease-up warning	<ul style="list-style-type: none"> • When the predetermined number of stitches has been reached. 	<ul style="list-style-type: none"> • Replenish the specified places with grease and reset. (For the details, refer to the data of the machine head.)
E221	Grease-up error	<ul style="list-style-type: none"> • When the predetermined number of stitches has been reached and the sewing is not possible. 	<ul style="list-style-type: none"> • Replenish the specified places with grease and reset. (For the details, refer to the data of the machine head.)

No.	Description of error detected	Cause of occurrence expected	Items to be checked
E302	Fall detection switch failure (When the safety switch works)	<ul style="list-style-type: none"> When fall detection switch is input in the state that the power is turned ON. Thread trimming knife position is not correct. Machine-head tilt detector's connector has come off. 	<ul style="list-style-type: none"> Check whether the machine head is tilted without turning OFF the power switch (sewing machine operation is prohibited for safety sake). Check whether the fall detection switch cord is caught in the sewing machine or the like. Check whether the fall detection switch lever is caught in something. Check whether the contact of the tilt detection switch lever with the machine table is inadequate. (The table has a dent or the mounting location of the bed strut is too far.) Check the machine-head tilt detector's connector (CN48) for looseness and slip-off.
E303	Semicircular plate sensor error	<ul style="list-style-type: none"> Semicircular plate sensor signal cannot be detected. 	<ul style="list-style-type: none"> Check whether the machine head corresponds with the machine type setting. Check whether the motor encoder connector is disconnected.
E331	Tape cutter device sensors are turned ON simultaneously	<ul style="list-style-type: none"> Faulty operation of the tape cutter device. 	<ul style="list-style-type: none"> Check whether the tape cutter device is connected properly. Check whether the pneumatic pressure is adequate.
E332	Tape cutter device sensors are turned OFF simultaneously	<ul style="list-style-type: none"> Faulty assembly and adjustment of the tape cutter device. 	<ul style="list-style-type: none"> Check whether the tape cutter device is properly assembled. Check whether the pneumatic pressure is adequate.
E499	Data fault	<ul style="list-style-type: none"> The stored data have broken. 	<ul style="list-style-type: none"> Reset all data on the function setting to the default values referring to "Initializing the function setting data" in the Engineer's Manual.
E704	Data fault	<ul style="list-style-type: none"> The stored data have broken. 	<ul style="list-style-type: none"> Reset all data on the function setting to the default values referring to "Initializing the function setting data" in the Engineer's Manual.
E730	Encoder failure	<ul style="list-style-type: none"> When the motor signal is not properly inputted. 	<ul style="list-style-type: none"> Check the motor signal connector (CN30) for loose connection and disconnection. Check whether the motor signal cord has broken since the cord is caught in the machine head. Check whether the inserting direction of the motor encoder connector is wrong.
E731	Motor hole sensor failure		
E733	Inverse rotation of motor	<ul style="list-style-type: none"> This error occurs when the motor is running at 500 sti/min or more in the opposite direction of that of rotation indication during motor is running. 	<ul style="list-style-type: none"> Connection of the encoder of main shaft motor is wrong. Connection for the electric power of main shaft motor is wrong.
E799	Thread trimming operation time-out	<ul style="list-style-type: none"> The thread trimmer control operation is not completed within the predetermined time period. 	<ul style="list-style-type: none"> Check whether the function setting No. 95 (Head selection function) has been set correctly. Check whether the motor pulley diameter agrees with the setting. Check whether the belt has slackened.
E808	Solenoid short circuit	<ul style="list-style-type: none"> Solenoid power does not become normal voltage. 	<ul style="list-style-type: none"> Check whether the machine head cord is caught in the pulley cover or the like.
E809	Holding motion failure	<ul style="list-style-type: none"> Solenoid is not changed over to holding motion. 	<ul style="list-style-type: none"> Check whether the solenoid is abnormally heated. (CTL circuit board asm. Circuit is broken.)
E810	Solenoid current abnormality	<ul style="list-style-type: none"> Solenoid rare short-circuit. 	<ul style="list-style-type: none"> Solenoid resistance.

No.	Description of error detected	Cause of occurrence expected	Items to be checked
E811	Overvoltage	<ul style="list-style-type: none"> • When voltage higher than guaranteed one is inputted. • 200V has been inputted to 100V specifications. • 220V is applied to 120V box. • CE : 400V is applied to 230V box. 	<ul style="list-style-type: none"> • Check whether the applied power voltage is higher than the rated voltage + (plus) 10% or more. • Check whether 100V/200V changeover connector is improperly set. <p>In the aforementioned cases, POWER p.c.b is broken.</p>
E813	Low voltage	<ul style="list-style-type: none"> • When voltage lower than guaranteed one is inputted. • 100V has been inputted to 200V specifications. • 120V is applied to 220V box. • Inner circuit is broken by the applied over-voltage. 	<ul style="list-style-type: none"> • Check whether the voltage is lower than the rated voltage - (minus) 10% or less. • Check whether 100V/200V changeover connector is improperly set. • Check whether fuse or regenerative resistance is broken.
E815	Regeneration resistor is not connected	<ul style="list-style-type: none"> • CN11: Not connected 	<ul style="list-style-type: none"> • Check whether the generation resistor is connected to CN11.
E906	Operation panel transmission failure	<ul style="list-style-type: none"> • Disconnection of operation panel cord. • Operation panel has broken. 	<ul style="list-style-type: none"> • Check the operation panel connector (CN38) for loose connection and disconnection. • Check whether the operation panel cord has broken since the cord is caught in the machine head.
E922	Main shaft uncontrollable	<ul style="list-style-type: none"> • In the case the main shaft cannot be controlled. 	<ul style="list-style-type: none"> • Turn the power OFF.
E924	Motor driver failure	<ul style="list-style-type: none"> • Motor driver has broken. 	
E930	Faulty encoder	<ul style="list-style-type: none"> • In the case a motor signal cannot be input correctly. 	<ul style="list-style-type: none"> • Check the motor signal connector (CN30) for looseness and slip-off. • Check whether the motor signal cord is caught in the machine head or has a break.
E931	Motor hole sensor failure		
E942	Faulty EEPROM	<ul style="list-style-type: none"> • Data cannot be written on the EEPROM. 	<ul style="list-style-type: none"> • Turn the power OFF.